



**PLEASE CHECK FOR CHANGE INFORMATION
AT THE REAR OF THIS MANUAL.**

**5A21N
DIFFERENTIAL
AMPLIFIER
WITH OPTIONS**

INSTRUCTION MANUAL

**Tektronix, Inc.
P.O. Box 500
Beaverton, Oregon 97077**

070-1139-01
Product Group 52

Serial Number _____

First Printing FEB 1971
Revised JUL 1982

Copyright © 1971, 1980 Tektronix, Inc. All rights reserved.
Contents of this publication may not be reproduced in any
form without the written permission of Tektronix, Inc.

Products of Tektronix, Inc. and its subsidiaries are covered
by U.S. and foreign patents and/or pending patents.

TEKTRONIX, TEK, SCOPE-MOBILE, and  are
registered trademarks of Tektronix, Inc. TELEQUIPMENT
is a registered trademark of Tektronix U.K. Limited.

Printed in U.S.A. Specification and price change privileges
are reserved.

INSTRUMENT SERIAL NUMBERS

Each instrument has a serial number on a panel insert, tag,
or stamped on the chassis. The first number or letter
designates the country of manufacture. The last five digits
of the serial number are assigned sequentially and are
unique to each instrument. Those manufactured in the
United States have six unique digits. The country of
manufacture is identified as follows:

| | |
|---------|---|
| B000000 | Tektronix, Inc., Beaverton, Oregon, USA |
| 100000 | Tektronix Guernsey, Ltd., Channel Islands |
| 200000 | Tektronix United Kingdom, Ltd., London |
| 300000 | Sony/Tektronix, Japan |
| 700000 | Tektronix Holland, NV, Heerenveen, The Netherlands |

5A21N
MOD 817H

PARTS LIST

Electrical

Add:

C9 281-0114-00

CAPACITOR, VAR, 1.6-4.86 pF, 530 V

Mechanical

Add:

030-0656-01
034-3031-00
162-0026-00
210-0203-00
210-0851-00
211-0159-00
343-0002-00

1 BLOCK, KEYING
1 CABLE, TWISTED PAIR, 12" LONG
1 INSUL SLEEVING, ELECTRICAL, 0.042 ID
1 TERMINAL, LUG, 0.146 ID, LOCKING
1 WASHER, FLAT, 0.119 ID x 0.025 THK, STL
1 SCREW, MACHINE, 2-56 x 0.375, PNH, STL
1 CLAMP, LOOP, 0.187 ID, PLASTIC

Change To:

034-0541-00

1 PANEL, FRONT

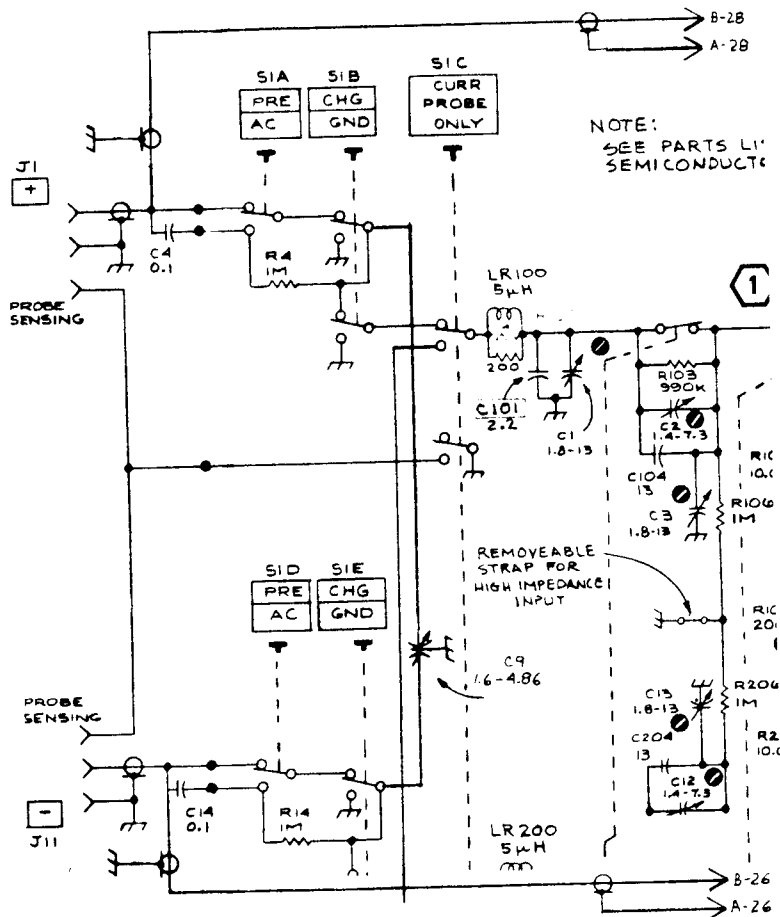

PARTIAL
DIFFERENTIAL AMPLIFIER

TABLE OF CONTENTS

| | |
|---|-------------|
| | Page |
| LIST OF ILLUSTRATIONS | iii |
| LIST OF TABLES | iii |
| OPERATORS SAFETY SUMMARY | iv |
| SERVICE SAFETY SUMMARY | v |

WARNING

THE FOLLOWING SERVICING INSTRUCTIONS ARE FOR USE BY QUALIFIED PERSONNEL ONLY. TO AVOID PERSONAL INJURY, DO NOT PERFORM ANY SERVICING OTHER THAN THAT CONTAINED IN OPERATING INSTRUCTIONS UNLESS YOU ARE QUALIFIED TO DO SO.

| | |
|--------------------------------------|-----|
| Section 1 GENERAL INFORMATION | |
| INTRODUCTION | 1-1 |
| INSTALLATION | 1-1 |
| EXTERIOR CLEANING | 1-1 |
| REPACKAGING FOR SHIPMENT | 1-1 |
| SPECIFICATION | 1-2 |
| RECOMMENDED ACCESSORIES | 1-6 |
| VOLTAGE PROBES | 1-6 |
| CURRENT PROBE | 1-6 |

| | |
|--|-----|
| Section 2 OPERATING INSTRUCTIONS | |
| CONTROLS AND CONNECTORS | 2-1 |
| OPERATORS CHECKOUT PROCEDURE | 2-1 |
| Test Equipment Required | 2-1 |
| Setup Procedure | 2-1 |
| Step Attenuator Balance Adjustment | 2-3 |
| Gain Check | 2-3 |
| DETAILED OPERATING INFORMATION | 2-3 |
| Applying Signals | 2-3 |
| Pre-Charging | 2-3 |
| Signal Input Connectors | 2-4 |
| Optional High Impedance Input (An Instrument Modification) | 2-4 |
| Display Polarity | 2-5 |
| Deflection Factor | 2-5 |
| Optional Bandwidth Limiting Frequencies (An Instrument Modification) | 2-5 |
| Voltage Comparison Measurements | 2-5 |
| Differential Operation | 2-6 |
| Voltage Probes | 2-6 |
| Current Probes | 2-8 |

| | |
|--------------------------------------|-------------|
| Section 3 THEORY OF OPERATION | Page |
| INTRODUCTION | 3-1 |
| BLOCK DIAGRAM | 3-1 |
| DETAILED CIRCUIT OPERATION | 3-1 |
| Plug-In Logic | 3-1 |
| Input Coupling | 3-2 |
| Current Probe Amplifier | 3-2 |
| Input Attenuators | 3-2 |
| Input Protection | 3-2 |
| Preamplifier Stage | 3-2 |
| Common-Mode Rejection | 3-3 |
| Isolation Stage | 3-4 |
| Output Amplifier | 3-4 |
| Trigger Output Amplifier | 3-4 |
| Attenuator Switching | 3-4 |
| Knob-Skirt Readout | 3-4 |

| | |
|---|-----|
| Section 4 MAINTENANCE | |
| PREVENTIVE MAINTENANCE | 4-1 |
| VISUAL INSPECTION | 4-1 |
| CLEANING | 4-1 |
| Exterior | 4-1 |
| Interior | 4-1 |
| SEMICONDUCTOR CHECKS | 4-1 |
| PERIODIC ELECTRICAL ADJUSTMENT | 4-1 |
| TROUBLESHOOTING | 4-2 |
| TROUBLESHOOTING AIDS | 4-2 |
| Diagrams | 4-2 |
| Circuit Board Illustrations | 4-2 |
| Component Color Coding | 4-2 |
| Semiconductor Lead Configurations | 4-2 |
| Troubleshooting Equipment | 4-2 |

5A21N
MOD 817H

c. Apply a 20 V peak-to-peak, 100 kHz sine-wave signal to pins A and C of the oscilloscope rear-panel Left Input connector.

NOTE

Cables from the sine-wave generator to pins A and C must be of equal length.

d. Set the 5A21N MOD 817H - Input Coupling to AC.

e. Set the 5A21N MOD 817H VOLTS/DIV switch to 60 μ V.

f. Adjust the 5A21N MOD 817H Input Balance control, C9 (accessible from the front panel through the hollow ground post), for minimum deflection.

TABLE OF CONTENTS (cont)

| Section 4 MAINTENANCE (cont) | Page | Section 5 CALIBRATION | Page |
|-------------------------------------|-------------|---|-------------|
| TROUBLESHOOTING | | USING THESE PROCEDURES . . . | 5-1 |
| TECHNIQUES | 4-4 | Performance Check Summary . . | 5-2 |
| 1. Check Control Settings | 4-4 | Test Equipment Required | 5-5 |
| 2. Check Associated Equipment | 4-4 | Special Fixtures | 5-5 |
| 3. Visual Check | 4-4 | Test Equipment Alternatives . . . | 5-5 |
| 4. Check Instrument Adjustment | 4-4 | PART I—PERFORMANCE CHECK . . . | 5-7 |
| 5. Isolate Trouble to a Circuit . . | 4-5 | INDEX TO PART I—PERFORMANCE | |
| 6. Check Voltages and | | CHECK | 5-7 |
| Waveforms | 4-5 | PRELIMINARY PROCEDURE FOR | |
| 7. Check Individual Components | 4-5 | PERFORMANCE CHECK | 5-7 |
| 8. Repair and Readjust the Circuit | 4-5 | PART II—ADJUSTMENT AND | |
| CORRECTIVE MAINTENANCE | 4-6 | PERFORMANCE CHECK | 5-12 |
| OBTAINING REPLACEMENT | | INDEX TO PART II—ADJUSTMENT | |
| PARTS | 4-6 | AND PERFORMANCE CHECK . . . | 5-12 |
| SOLDERING TECHNIQUES | 4-6 | PRELIMINARY PROCEDURE FOR | |
| COMPONENT REMOVAL AND | | ADJUSTMENT AND | |
| REPLACEMENT | 4-7 | PERFORMANCE CHECK | 5-12 |
| SEMICONDUCTOR REPLACEMENT | 4-7 | Section 6 INSTRUMENT OPTIONS | |
| CAM SWITCH REPLACEMENT AND | | Section 7 REPLACEABLE ELECTRICAL PARTS | |
| LUBRICATION | 4-8 | Section 8 DIAGRAMS AND CIRCUIT BOARD | |
| OPTIONAL HIGH IMPEDANCE | | ILLUSTRATIONS | |
| INPUT (A USER MODIFICATION) . | 4-8 | Section 9 REPLACEABLE MECHANICAL PARTS | |
| OPTIONAL BANDWIDTH LIMITING | | CHANGE INFORMATION | |
| FREQUENCIES (A USER | | | |
| MODIFICATION) | 4-9 | | |
| ADJUSTMENT AFTER REPAIR . . . | 4-9 | | |

5A21N
MOD 817H

This manual insert describes MOD 817H as it applies to the TEKTRONIX 5A21N Differential Amplifier plug-in unit. The instrument is equipped with parallel connections to both front-panel voltage input connectors from the interface connector, for input via rear-panel connectors of a suitably-modified oscilloscope. A differential capacitor has been added at the inputs to correct typical shunt capacitance imbalances in plug-in and mainframe cables. The instrument is keyed against insertion in unmodified oscilloscopes.

CHARACTERISTICS

Input Characteristic. Low-frequency shunt input RC characteristic at each voltage input connector consists of the parallel combination of the following:

1. Normal 5A21N input characteristic: $1\text{ M}\Omega$, 47 pF .
2. Added cable capacitance in the plug-in unit: $<40\text{ pF}$.
3. Cable and connector capacitance in the (modified) oscilloscope: typically not over 30 pF .
4. Characteristics of cables or circuits attached to the opposite input.

Compatibility. This instrument may be inserted only in plug-in compartments of oscilloscopes modified with compatible interface connections. For operation at sensitivities of $50\text{ }\mu\text{V/div}$, only an oscilloscope modified with twisted-coaxial-pairs for rear input lines (MODs 817C or 817D) should be used. Where separate cables and single-contact (e.g., bnc) connectors are used, interference from magnetic fields will be excessive for operation in the $50\text{ }\mu\text{V/div}$ to 0.5 mV/div range.

Probes. Input capacitance is beyond the compensation of conventional passive attenuator probes, and their use is not recommended. Probes of the X1 type may be used normally (with no connection to the opposite paralleled input) with allowance for increased capacitive loading of the signal source.

CALIBRATION

Calibrate the 5A21N MOD 817H as outlined in the 5A21N instruction manual, then perform the following steps.

Additional Test Equipment Required -- 5100-Series Oscilloscope MOD 817C, or equivalent

- a. Insert the 5A21N MOD 817H in the left (vertical) plug-in compartment of the oscilloscope.
- b. Set the 5A21N MOD 817H + Input Coupling to 5 V/div AC and the - Input Coupling to GND.

LIST OF ILLUSTRATIONS

| Fig. No. | | Page |
|---------------------|--|-------------|
| | 5A21N Features | vi |
| 2-1 | Front-panel controls, connectors and indicators | 2-2 |
| 2-2 | Improving signal-to-noise ratio by setting bandwidth; (A) signal applied with the BANDWIDTH LIMIT switch set to 1 MHz, (B) same signal with the BANDWIDTH LIMIT switch set to 10 kHz | 2-5 |
| 2-3 | Three examples of differential applications | 2-7 |
| 3-1 | Preamplifier detailed block diagram showing signal current paths | 3-3 |
| 3-2 | Floating Power Supply detailed block diagram showing standing current paths through the Preamplifier | 3-3 |
| 4-1 | Color code for resistors and capacitors | 4-3 |
| 4-2 | Semiconductor lead configurations | 4-4 |
| 4-3 | Lubrication procedure for a typical cam switch | 4-8 |
| 5-1 | Adjustment locations | 5-14 |

LIST OF TABLES

| Table No. | | Page |
|----------------------|---|-------------|
| 1-1 | Electrical Characteristics | 1-2 |
| 1-2 | Environmental Characteristics | 1-5 |
| 1-3 | Physical Characteristics | 1-5 |
| 4-1 | Optional Bandwidth Limiting | 4-9 |
| 5-1 | Calibration Procedure Electives | 5-1 |
| 5-2 | Performance Check Summary | 5-2 |
| 5-3 | Test Equipment | 5-5 |
| 5-4 | Volts/Division Accuracy | 5-8 |
| 5-5 | Volts/Division Accuracy | 5-15 |

OPERATORS SAFETY SUMMARY

The general safety information in this part of the summary is for both operating and servicing personnel. Specific warnings and cautions will be found throughout the manual where they apply, but may not appear in this summary.

Terms In This Manual

CAUTION statements identify conditions or practices that could result in damage to the equipment or other property.

WARNING statements identify conditions or practices that could result in personal injury or loss of life.

Terms As Marked on Equipment

CAUTION indicates a personal injury hazard not immediately accessible as one reads the marking, or a hazard to property including the equipment itself.

DANGER indicates a personal injury hazard immediately accessible as one reads the marking.

Power Source

This product is intended to operate in a mainframe connected to a power source that will not apply more than 250 volts rms between the supply conductors or between either supply conductor and ground. A protective ground connection by way of the grounding conductor in the mainframe power cord is essential for safe operation.

Grounding the Product

This product is grounded through the grounding conductor of the power cord. To avoid electrical shock, plug the power cord into a properly wired receptacle before connecting to the product input or output terminals. A protective ground connection by way of the grounding conductor in the power cord is essential for safe operation.

Danger Arising From Loss of Ground

Upon loss of the protective-ground connection, all accessible conductive parts (including knobs and controls that may appear to be insulating) can render an electric shock.

Do Not Operate in Explosive Atmospheres

To avoid explosion, do not operate this product in an explosive atmosphere unless it has been specifically certified for such operation.

Do Not Operate Plug-In Unit Without Covers

To avoid personal injury, do not operate this product without covers or mainframe panels installed. Do not apply power to the plug-in via a plug-in extender.

TEKTRONIX®

This insert is provided as a supplement to the instruction manual furnished with this modified instrument. The information given in this insert supersedes that given in the manual.

This insert material Copyright © 1973 by Tektronix, Inc., Beaverton, Oregon. Printed in the United States of America. All rights reserved. Contents of this insert may not be reproduced in any form without permission of the copyright owner.

5A21N

MOD 817H

M280

MODIFICATION INSERT

SERVICE SAFETY SUMMARY

FOR QUALIFIED SERVICE PERSONNEL ONLY

Refer also to the preceding Operators Safety Summary.

Do Not Service Alone

Do not perform internal service or adjustment of this product unless another person capable of rendering first aid and resuscitation is present.

Use Care When Servicing With Power On

Dangerous voltages exist at several points in this product. To avoid personal injury, do not touch exposed connections and components while power is on.

Disconnect power before removing protective covers, soldering, or replacing components.

Power Source

This product is intended to operate in a mainframe connected to a power source that will not apply more than 250 volts rms between the supply conductors or between either supply conductor and ground. A protective ground connection by way of the grounding conductor in the mainframe power cord is essential for safe operation.

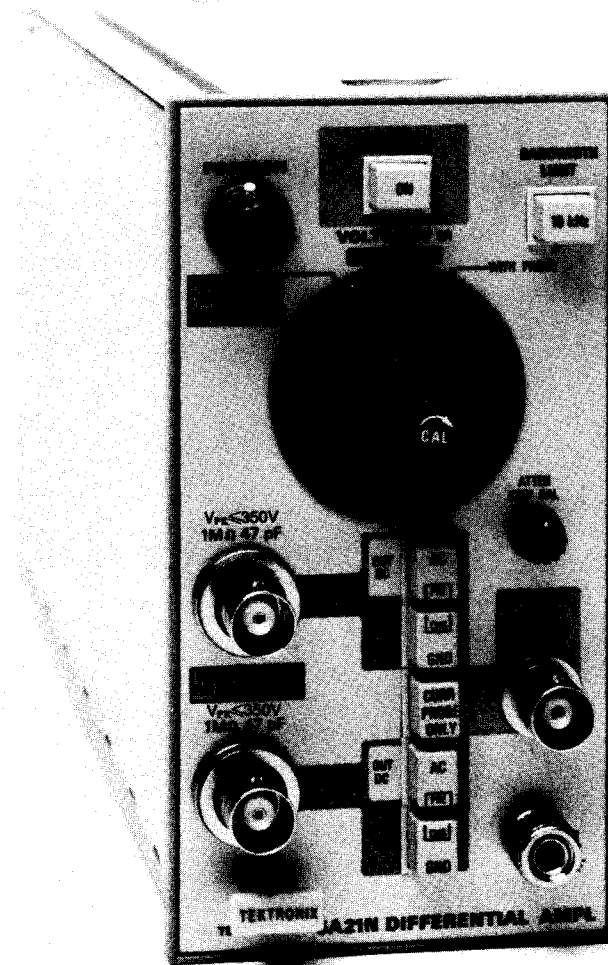

5A21N FEATURES

The 5A21N Differential Amplifier is a high-gain differential amplifier plug-in unit for use with Tektronix 5000-series oscilloscopes, and permits the measurement of current signals as well as voltage signals. The unit features high sensitivity with direct-coupled inputs ($50 \mu\text{V}/\text{DIV}$ or $0.5 \text{ mA}/\text{DIV}$), and has a high common-mode rejection ratio. An illuminated knob skirt provides deflection factor readout. The unit has a bandwidth capability of dc to one megahertz, and a front-panel pushbutton switch allows reduction of the upper bandwidth limit, thus increasing the signal-to-noise ratio for low-frequency applications. A P6021 Current Probe is included with the Option 01 instrument.

1139-01

5A21N Features

MANUAL CHANGE INFORMATION

At Tektronix, we continually strive to keep up with latest electronic developments by adding circuit and component improvements to our instruments as soon as they are developed and tested.

Sometimes, due to printing and shipping requirements, we can't get these changes immediately into printed manuals. Hence, your manual may contain new change information on following pages.

A single change may affect several sections. Since the change information sheets are carried in the manual until all changes are permanently entered, some duplication may occur. If no such change pages appear following this page, your manual is correct as printed.

GENERAL INFORMATION

INTRODUCTION

This Instruction Manual is divided into two main sections, Operators information and Servicing information. The content of the Operators information is divided into the following sections:

Section 1— General Information contains instrument description, electrical specifications, environmental characteristics, recommended accessories, installation, and repackaging for shipment instructions.

Section 2— Operating Instructions contains information relative to operating and checking the instrument operation.

WARNING

THE REMAINING PORTIONS OF THIS INSTRUCTION MANUAL (SECTIONS AFTER SECTION 1 AND 2) CONTAIN SERVICING INSTRUCTIONS. THESE SERVICING INSTRUCTIONS ARE FOR USE BY QUALIFIED SERVICE PERSONNEL ONLY. TO AVOID ELECTRIC SHOCK OR OTHER PERSONAL INJURY, DO NOT PERFORM ANY SERVICING OTHER THAN THAT DESCRIBED IN THE OPERATING INSTRUCTIONS UNLESS YOU ARE QUALIFIED TO DO SO.

INSTALLATION

Initial Inspection

WARNING

Dangerous voltages exist inside the instrument. To avoid electrical-shock hazards, operating personnel must not remove protective instrument covers. Component replacement and internal adjustments must be made by qualified service personnel only.

This instrument was checked both mechanically and electrically before shipment from the factory and it should be free of marks or scratches and should meet or exceed all electrical specifications. To confirm this, inspect the instrument for physical damage incurred in transit. Test the electrical performance by following the Operators Checkout Procedure in section 2 and then refer qualified service personnel to the Performance Check Procedure in this Instruction Manual. If there is damage or deficiency,

contact your local Tektronix Field Office or representative.

Initial Operating Information

CAUTION

To prevent instrument damage, plug-in units should not be installed or removed without first turning off the mainframe power.

The 5A21N can be installed in any compartment of Tektronix 5000-series oscilloscopes, but is intended principally for use in vertical plug-in compartments. To install, align the upper and lower rails of the 5A21N with the oscilloscope tracks and insert. The 5A21N front panel will be flush with the front of the oscilloscope and the latch at the bottom left corner of the 5A21N will be in place against the front panel when the 5A21N is fully installed.

To remove the 5A21N, pull on the release latch and the 5A21N will unlatch. Continue pulling to slide the 5A21N out of the oscilloscope.

Operating Temperature

The 5A21N can be operated where the ambient air temperature is between 0° and +50°C and can be stored in ambient temperatures from -40°C to +70°C. After storage at temperatures outside the operating limits, allow the chassis temperature to reach a safe operating temperature before applying power.

EXTERIOR CLEANING

Loose dust accumulated on the outside of the instrument can be removed with a soft cloth or small brush. The brush is particularly useful for dislodging dirt on and around the front-panel controls. Dirt which remains can be removed with a soft cloth dampened in a mild detergent and water solution. Abrasive cleaners should not be used.

REPACKAGING FOR SHIPMENT

If this instrument is to be shipped for long distances by commercial transportation, we recommend that the instrument be packaged in the original manner. The carton

General Information—5A21N

and packaging material in which your instrument was shipped should be saved for this purpose.

If this instrument is to be shipped to a Tektronix Service Center for service or repair, attach a tag to the instrument showing the following: Owner of the instrument (with address), the name of the person at your firm who can be contacted, complete instrument type and serial number, and a description of the service required.

If the original packaging is unfit for use or not available, package the instrument as follows:

1. Obtain a corrugated cardboard carton with at least a 200-pound test strength and dimensions at least six inches larger than the instrument's dimensions.
2. Surround the instrument with polyethylene sheeting, or equivalent, to protect the instrument.
3. Allow a 3-inch cushion on all sides by tightly packing dunnage or urethane foam between the carton and the instrument.
4. Seal the carton with shipping tape or with an industrial stapler.
5. Mark the address of the Tektronix Service Center and your return address in one or more prominent locations on the exterior of the shipping carton.

SPECIFICATION

In this manual Volts/Div, Seconds/Div or division refers to major graticule division.

The following electrical characteristics are valid only if the instrument has been calibrated at an ambient temperature between +20°C and +30°C, the instrument is operating at an ambient temperature between 0°C and +50°C (unless otherwise specified), and the instrument is operating (fully installed) in a calibrated system.

Items listed in the Performance Requirements column of the Electrical Characteristics are verified by completing checkout procedures in this manual (the procedures are for qualified personnel only). Some items listed in the Supplemental Information column are verified in this manual. The Supplemental Information items that are not verified are either explanatory notes or performance characteristics for which no limits are specified.

Table 1-1

ELECTRICAL CHARACTERISTICS

| Characteristics | Performance Requirement | Supplemental Information |
|-------------------------|----------------------------|--|
| Deflection Factor | | |
| VOLTS/DIV | | |
| Calibrated Range | 50 μ V/div to 5 V/div. | 16 steps in a 1-2-5 sequence. |
| Accuracy | Within 2%. | 2% accuracy maintained when used with a P6060 probe, 3% with P6062B or P6055. |
| AMPERES/DIV | | |
| Calibrated Range | 0.5 mA/div to 0.5 A/div. | 10 steps in a 1-2-5 sequence. |
| Accuracy | Within 3%. | |
| Step Attenuator Balance | | Adjustable for one division or less trace movement as VOLTS/DIV is rotated throughout its range. |

| Fig. & Index No. | Tektronix Part No. | Serial/Model No. Eff Dscont | Qty | 1 | 2 | 3 | 4 | 5 | Name & Description | Mfr Code | Mfr Part Number |
|------------------------|-----------------------|-------------------------------------|-----|---|---|---|---|---|---------------------------------|-------------|-----------------|
| STANDARD ACCESSORIES | | | | | | | | | | | |
| | 070-1139-01 | | 1 | | | | | | MANUAL, TECH: | 80009 | 070-1139-01 |
| | 010-0237-02 | | 1 | | | | | | PROBE CURRENT: 60.0 L, W/ACCESS | 80009 | 010-0237-02 |
| | ----- | | - | | | | | | (OPTION 1 ONLY) | | |

Table 1-1 (cont)

| Characteristics | Performance Requirement | Supplemental Information |
|---------------------------------------|---|---|
| Uncalibrated (CAL) Range | | At least 2.5:1. |
| Frequency Response | | |
| Bandwidth (8 Div Reference) | | |
| DC (Direct) Coupled | | |
| 1 MHz | DC to at least 1 MHz. | |
| 10 kHz | DC to \approx 10 kHz. | Within 20%; frequency may be user modified. |
| AC (Capacitive) Coupled | | |
| 1 MHz | 2 Hz or less to at least 1 MHz. | |
| 10 kHz | 2 Hz or less to \approx 10 kHz. | Within 20%; frequency may be user modified. |
| AMPERES Mode | | |
| 1 MHz | 15 Hz or less to at least 1 MHz. | |
| 10 kHz | 15 Hz or less to \approx 10 kHz. | Within 20%; frequency may be user modified. |
| Step Response (Displayed) Aberrations | +2%, -2% or less, total of 3% or less of pulse amplitude. | |
| Inputs | | |
| Voltage Mode | | |
| Resistance | 1 M Ω , within 0.14%. | Time constant normalized for 47 μ s, within 3% between channels; may be user modified for high impedance input. |
| Capacitance | \approx 47 pF. | |
| Maximum Safe Input Voltages | | |
| DC (Direct) Coupled | | |
| 50 μ V/div to 50 mV/div | 10 V (DC + Peak AC) | |
| 100 mV/div to 5 V/div | 350 V (DC + Peak AC) | |
| AC (Capacitive) Coupled | | |
| 50 μ V/div to 50 mV/div | 350 V DC (Coupling capacitor precharged), 10 V peak AC. | |
| 100 mV/div to 5 V/div | 350 V (DC + Peak AC) | |
| DC Rejection, AC (Capacitive) Coupled | At least 100,000:1 after 20 minutes warmup. | |

Table 1-1 (cont)

| Characteristics | Performance Requirement | Supplemental Information |
|---|--|--|
| Input Gate Current | 100 pA or less (equivalent to 100 μ V or less, depending on external loading) at 25°C | |
| Current Mode Maximum Equivalent Input | 4 A peak to peak (at probe tip) with 125-turn current probe. | |
| POSITION Range | | At least + and – 10 divisions from graticule center. |
| Common Mode Rejection DC (Direct) Coupled | At least 100,000:1 (100 dB), DC to 30 kHz at 50 μ V/div and 0.1 mV/div with up to 20 V peak-to-peak sine wave, decreasing by less than 20 dB/decade on lower sensitivity ranges up to 50 mV/div. From 100 mV/div to 5 V/div, CMRR is at least 400:1 (52 dB) with up to 100 V peak-to-peak sine wave. | CMRR with two P6060 probes is at least 400:1 (52 dB) at any deflection factor. |
| AC (Capacitive) Coupled 50 μ V/div to 0.5 mV/div | At least 10,000:1 (80 dB) at 5 kHz and above, decreasing to 400:1 (52 dB) at 10 Hz. | |
| Displayed Noise (Tangentially Measured) | 30 μ V or less. | |

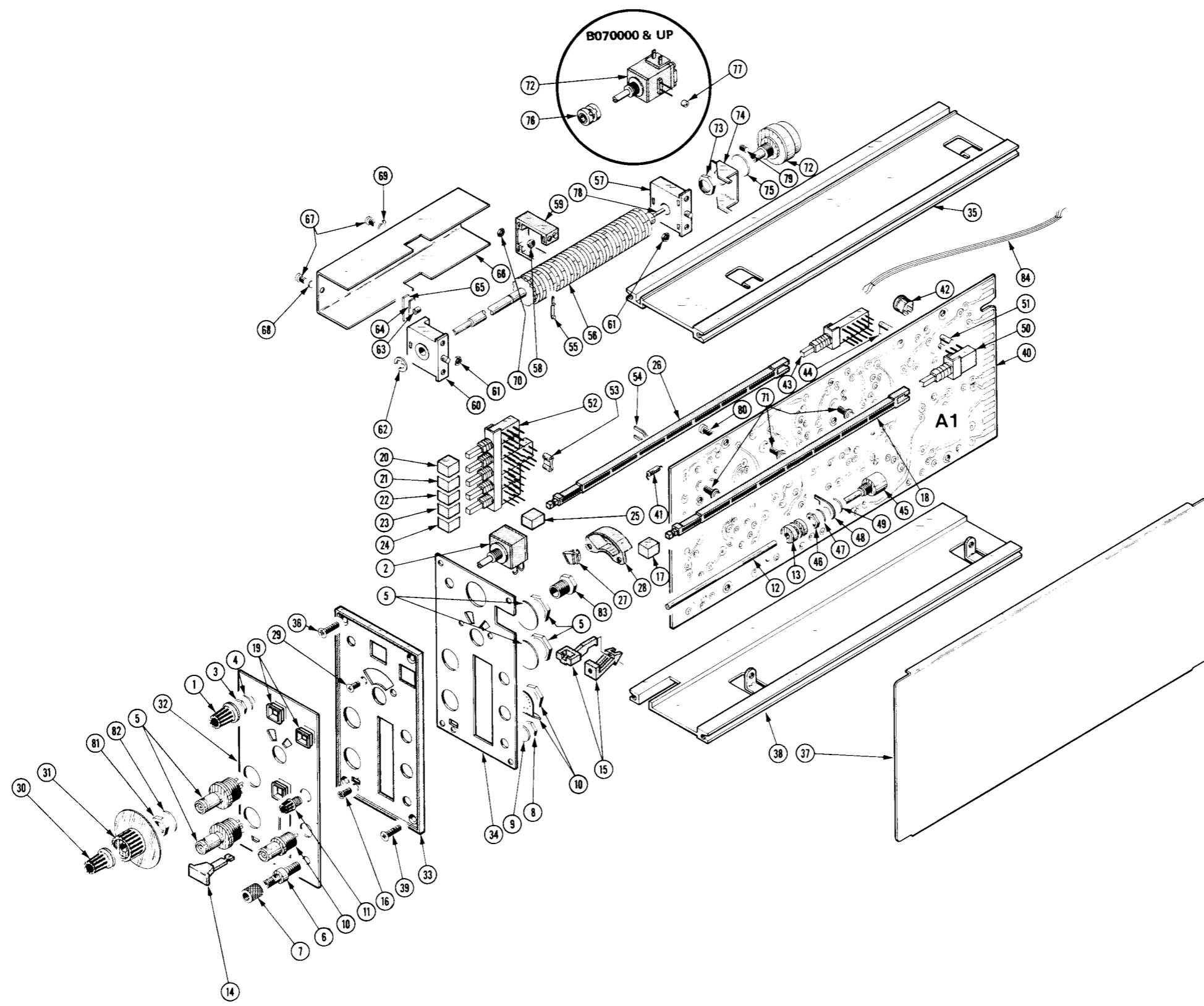

FIG. 1 EXPLODED

REV B MAY 1980

5A21N

Table 1-2
ENVIRONMENTAL CHARACTERISTICS

| Characteristics | Description |
|-------------------------------|--|
| Temperature | |
| Calibration Range | +20°C to +30°C (+68°F to +86°F). |
| Operating Range | 0°C to +50°C (+32°F to +122°F). |
| Non-operating Range (Storage) | -40°C to +70°C (-40°F to +158°F). |
| Altitude | |
| Operating Range | To 4.95 km (15,000 feet). |
| Non-operating Range (Storage) | To 15.15 km (50,000 feet). |
| Vibration | |
| Operating and Non-operating | With the instrument complete and operating, vibration frequency swept from 10 to 50 to 10 Hz at 1 minute per sweep. Vibrate 15 minutes in each of the three axes at 0.015" (0.038 cm) total displacement. Hold 3 minutes at any resonance, or if none, at 50 Hz. Total time, 54 minutes. |
| Shock | |
| Operating and Non-operating | 30 g's, 1/2 sine, 11 ms duration, 2 shocks in each direction, along 3 major axes for a total of 12 shocks. |
| Transportation | Qualified under National Safe Transit Committee Test Procedure 1A, Category II. |

Table 1-3
PHYSICAL CHARACTERISTICS

| Characteristics | Description |
|--------------------|--|
| Overall Dimensions | 6.6 cm (2.6 in) W X 30 cm (11.8 in) D X 11.9 cm (4.7 in) H |
| Net Weight | Approximately 0.8 kg (1.8 lb). |
| Finish | Anodized aluminum panel and chassis. |

RECOMMENDED ACCESSORIES

The following accessories have been selected from our catalog specifically for your instrument. They are listed as a convenience to help you meet your measurement needs. For detailed information and prices, refer to a Tektronix Products Catalog or contact your local Tektronix Field Representative.

VOLTAGE PROBES

P6060

The P6060 is a passive 10X attenuating probe providing precision attenuation and full bandwidth at low cost. When used in pairs, can give up to 400:1 common-mode rejection ratio.

P6062B

The P6062B is a passive 1X/10X attenuating probe providing switchable attenuation and full bandwidth.

P6055

The P6055 is a miniature, low-capacitance passive probe having an attenuation ratio adjustable to 10X. When used in pairs, can give up to 20,000:1 common mode rejection ratio.

CURRENT PROBE

P6021

The P6021 is a passive ac current probe that permits full-bandwidth current waveforms to be viewed and measured on the 5A21N Amplifier—oscilloscope system (provided with Option 01).

Replaceable Mechanical Parts—5A21N

| Fig. & Index No. | Tektronix Part No. | Serial/Model No. Eff Dscont | Qty | 1 | 2 | 3 | 4 | 5 | Name & Description | Mfr Code | Mfr Part Number |
|-----------------------------------|--------------------|-----------------------------|-----|---|---|---|---|---|---|----------|-----------------|
| (ATTACHING PARTS FOR CKT BD ASSY) | | | | | | | | | | | |
| 1-80 | 213-0146-00 | | 4 | | | | | | SCR,TPG,THD FOR:6-20 X 0.313 INCH,PNH STL | 83385 | OBD |
| -81 | 210-0590-00 | | 1 | | | | | | NUT,PLAIN,HEX.:0.375 X 0.438 INCH,STL | 73743 | 2X28269-402 |
| -82 | 210-0978-00 | | 1 | | | | | | WASHER,FLAT:0.375 ID X 0.50 INCH OD,STL | 78471 | OBD |
| -83 | 358-0029-00 | | 1 | | | | | | BSHG,MACH.THD:HEX,0.375-32 X 0.438"LONG | 80009 | 358-0029-00 |
| | 198-2020-00 | | 1 | | | | | | WIRE SET,ELEC: | 80009 | 198-2020-00 |
| -84 | 175-0826-00 | | FT | | | | | | . WIRE,ELECTRICAL:3 WIRE RIBBON | 80009 | 175-0826-00 |

OPERATING INSTRUCTIONS

The 5A21N Differential Amplifier Plug-In operates with a Tektronix 5000-series oscilloscope system. To use the 5A21N effectively, the operation and capabilities of the instrument must be known. This section describes front-panel control functions, general information on signal input connections, and other subjects that pertain to various measurement applications.

CONTROLS AND CONNECTORS

The 5A21N front panel is shown in Fig. 2-1. A brief, functional description of each control and connector is included in the illustration. Refer to Detailed Operating Information for additional information.

OPERATORS CHECKOUT PROCEDURE

The following procedure can be used for incoming inspection to verify proper operation, and may also be used by the operator for instrument familiarization. Only instrument functions (not measurement quantities or specifications) are checked in the procedure; therefore, a minimum amount of test equipment is required. If performing the Operators Checkout Procedure reveals improper performance or instrument malfunction, first check the operation of associated equipment; then refer to qualified service personnel for repair or adjustment of the instrument.

Test Equipment Required

The following test equipment was used in preparing the Operators Checkout Procedure. Other test equipment that meets these requirements may be substituted. When other equipment is substituted, the control settings or setup may need to be altered.

1. 5000-series oscilloscope mainframe (e.g., 5110, 5111, 5115, 5440, or 5441).

2. 5B-series time-base unit (e.g., 5B10N, 5B12N in any 5000-series mainframe; 5B40, 5B42 in a 5400-series mainframe).

3. 1X Probe: TEKTRONIX P6062B Passive Probe or test lead.

4. Dual-Input Cable: 50 Ω coaxial, Tektronix 067-0525-01 Calibration Fixture.

Setup Procedure

The first few steps of the following procedure are intended to help place the trace on the screen quickly and prepare the instrument for immediate use. The remainder of the steps demonstrate some of the basic functions of the 5A21N. Operation of other instruments in the system is described in the manuals for those units.

1. With the 5000-series oscilloscope power switch in the off position, connect the oscilloscope to a suitable power source.

2. Install the 5A21N in the left vertical compartment of the oscilloscope system. To install, align the upper and lower rails of the 5A21N with the plug-in compartment tracks and fully insert it (the plug-in panel must be flush with the oscilloscope panel).

3. Install the 5B-series time-base unit in the horizontal compartment of the oscilloscope system.

4. Turn the oscilloscope Intensity control fully counterclockwise and turn the oscilloscope system Power on. Preset the time-base and triggering controls for a 2 ms/div sweep rate and automatic triggering.

5. Set the 5A21N front-panel controls as follows:

| | |
|--------------------|------------------------------|
| DISPLAY | ON (readout illuminates) |
| POSITION | Midrange |
| BANDWIDTH LIMIT | 1 MHz (button out) |
| CURR PROBE ONLY | VOLTS (button out) |
| VOLTS/DIV | .1 V |
| Variable Volts/Div | CAL detent (fully clockwise) |
| ATTEN STEP BAL | Midrange |
| + Input Coupling | DC, GND |
| – Input Coupling | DC, GND |

Replaceable Mechanical Parts—5A21N

| Fig. & Index No. | Tektronix Part No. | Serial/Model No. Eff | Discont | Qty | 1 2 3 4 5 | Name & Description | Mfr Code | Mfr Part Number |
|------------------|--------------------|----------------------|----------|-----|-----------|---|----------|------------------|
| 1-34 | 337-1396-00 | B010100 | B084880 | 1 | | SHIELD,ELEC:REAR | 80009 | 337-1396-00 |
| | 337-1396-01 | B084881 | | 1 | | SHIELD,ELEC:REAR | 80009 | 337-1396-01 |
| | | | | | | (ATTACHING PARTS) | | |
| | 211-0502-00 | XB084881 | | 2 | | SCREW,MACHINE:6-32 X 0.188",FLH STL | 83385 | OBD |
| -35 | 426-0725-00 | | | 1 | | FR SECT,PLUG-IN:TOP | 80009 | 426-0725-00 |
| | | | | | | (ATTACHING PARTS) | | |
| -36 | 213-0229-00 | | | 2 | | SCR,TPG,THD FOR:6-20 X0.375"100 DEG,FLH STL | 93907 | OBD |
| -37 | 337-1399-00 | | | 2 | | SHLD,ELECTRICAL:SIDE | 80009 | 337-1399-00 |
| -38 | 426-0724-00 | | | 1 | | FR SECT,PLUG-IN:BOTTOM | 80009 | 426-0724-00 |
| | | | | | | (ATTACHING PARTS) | | |
| -39 | 213-0229-00 | | | 2 | | SCR,TPG,THD FOR:6-20 X0.375"100 DEG,FLH STL | 93907 | OBD |
| -40 | ----- | | | 1 | | CKT BOARD ASSY:MAIN(SEE A1 REPL) | | |
| -41 | 131-0566-00 | | | 1 | | . BUS CONDUCTOR:DUMMY RES,2.375,22 AWG | 55210 | L-2007-1 |
| -42 | 136-0235-00 | | | 5 | | . SOCKET,PLUG-IN:6 CONTACT,ROUND | 71785 | 133-96-12-062 |
| -43 | ----- | | | 1 | | . SWITCH,PUSH:(SEE S180 REPL) | | |
| -44 | 361-0383-00 | | | 2 | | . SPACER,PB SW:CHARCOAL,0.33 INCH LONG | 80009 | 361-0383-00 |
| -45 | ----- | | | 1 | | . RESISTOR,VAR:(SEE R109 REPL) | | |
| | | | | | | (ATTACHING PARTS) | | |
| -46 | 210-0583-00 | | | 1 | | . NUT,PLAIN,HEX:0.25-32 X 0.312 INCH,BRS | 73743 | 2X20317-402 |
| -47 | 210-0046-00 | | | 1 | | . WASHER,LOCK:0.261 ID,INTL,0.018 THK,BRS | 78189 | 1214-05-00-0541C |
| -48 | 387-0794-00 | | | 1 | | . PLATE,CMPNT MTG:VAR RESISTOR,BRASS | 80009 | 387-0794-00 |
| -49 | 210-0940-00 | | | 1 | | . WASHER,FLAT:0.25 ID X 0.375 INCH OD,STL | 79807 | OBD |
| -50 | ----- | | | 1 | | . SWITCH,PUSH:(SEE S259 REPL) | | |
| -51 | 361-0385-00 | | | 2 | | . SPACER,PB SW:0.164 INCH LONG | 80009 | 361-0385-00 |
| -52 | ----- | | | 1 | | . SWITCH,PUSH:(SEE S1 REPL) | | |
| -53 | 361-0384-00 | | | 5 | | . SPACER,PB SW:0.133 INCH LONG | 80009 | 361-0384-00 |
| -54 | 344-0154-00 | | | 4 | | . CLIP,ELECTRICAL:FUSE,CKT BD MT | 80009 | 344-0154-00 |
| -55 | 131-0604-00 | | | 13 | | . CONTACT,ELEC:CKT BD SW,SPR,CU BE | 80009 | 131-0604-00 |
| -56 | 105-0239-00 | | | 1 | | . ACTR ASSY,CAM S:VOLT/DIV | 80009 | 105-0239-00 |
| | 105-0221-00 | | | 1 | | . . ACTUATOR,CAM SW:VOLT/DIV | 80009 | 105-0221-00 |
| -57 | 401-0056-00 | | | 1 | | . . BEARING,CAM SW:REAR | 80009 | 401-0056-00 |
| -58 | 220-0636-00 | | | 2 | | . . NUT,PLAIN,HEX.:2-56 X 0.188 INCH HEX,BRS | 73743 | OBD |
| -59 | 407-0653-00 | | | 1 | | . . BRACKET,COVER:CAM SWITCH,DELTRIN | 80009 | 407-0653-00 |
| -60 | 401-0057-00 | | | 1 | | . . BEARING,CAM SW:FRONT | 80009 | 401-0057-00 |
| -61 | 210-0406-00 | | | 6 | | . . NUT,PLAIN,HEX.:4-40 X 0.188 INCH,BRS | 73743 | 12161-50 |
| | 131-1219-00 | XB040000 | | 1 | | . . CONTACT,ELEC:GROUNDING | 80009 | 131-1219-00 |
| -62 | 354-0219-00 | | | 1 | | . . RING,RETAINING:FOR 0.25 INCH SHAFT | 79136 | 5103-25-MD-R |
| -63 | 214-1127-00 | | | 1 | | . . ROLLER,DETENT:0.125 DIA X 0.125,SST | 80009 | 214-1127-00 |
| -64 | 214-1139-03 | | | 1 | | . . SPRING,FLAT:RED COLORED | 80009 | 214-1139-03 |
| -65 | 214-1139-02 | | | 1 | | . . SPRING,FLAT:GREEN COLORED | 80009 | 214-1139-02 |
| -66 | 200-0943-01 | | | 1 | | . . COVER,CAM SW:36 ELEMENTS | 80009 | 200-0943-01 |
| | | | | | | (ATTACHING PARTS) | | |
| -67 | 211-0079-00 | | | 4 | | . . SCREW,MACHINE:2-56 X 0.188 INCH,PNH STL | 77250 | OBD |
| -68 | 210-0001-00 | | | 3 | | . . WASHER,LOCK:INTL,0.092 ID X 0.18"OD,STL | 78189 | 1202-00-00-0541C |
| -69 | 210-0259-00 | | | 1 | | . . TERMINAL,LUG:0.099"ID INT TOOTH,SE | 80009 | 210-0259-00 |
| -70 | 220-0636-00 | | | 2 | | . . NUT,PLAIN,HEX.:2-56 X 0.188 INCH HEX,BRS | 73743 | OBD |
| | | | | | | (ATTACHING PARTS FOR ACTR ASSY) | | |
| -71 | 211-0116-00 | | | 6 | | . SCR,ASSEM WSHR:4-40 X 0.312 INCH,PNH BRS | 83385 | OBD |
| | 334-3448-00 | XB073269 | | 1 | | . . MARKER,IDENT:MARKED NOTICE | 80009 | 334-3448-00 |
| -72 | ----- | | | 1 | | . RESISTOR,VAR:(SEE R169 REPL) | | |
| | | | | | | (ATTACHING PARTS) | | |
| -73 | 210-0590-00 | B010100 | B069999X | 1 | | . NUT,PLAIN,HEX.:0.375 X 0.438 INCH,STL | 73743 | 2X28269-402 |
| -74 | 407-0894-00 | B010100 | B069999X | 1 | | . BRACKET,ELEC SW:BRASS | 80009 | 407-0894-00 |
| -75 | 210-0012-00 | B010100 | B069999X | 1 | | . WASHER,LOCK:INTL,0.375 ID X 0.50" OD STL | 78189 | 1220-02-00-0541C |
| -76 | 376-0050-00 | XB070000 | | 1 | | . CPLG,SHAFT,FLEX:FOR 0.081/0.125 INCH SHAFTS | 80009 | 376-0050-00 |
| -77 | 361-0385-00 | | | 1 | | . SPACER,PB SW:0.164 INCH LONG | 80009 | 361-0385-00 |
| -78 | 384-0242-00 | | | 1 | | . EXTENSION SHAFT:7.281 L X 0.125 STEP OD | 80009 | 384-0242-00 |
| | | | | | | (ATTACHING PARTS) | | |
| -79 | 213-0048-00 | | | 1 | | . SETSCREW:4-40 X 0.125 INCH,HEX SOC STL | 74445 | OBD |

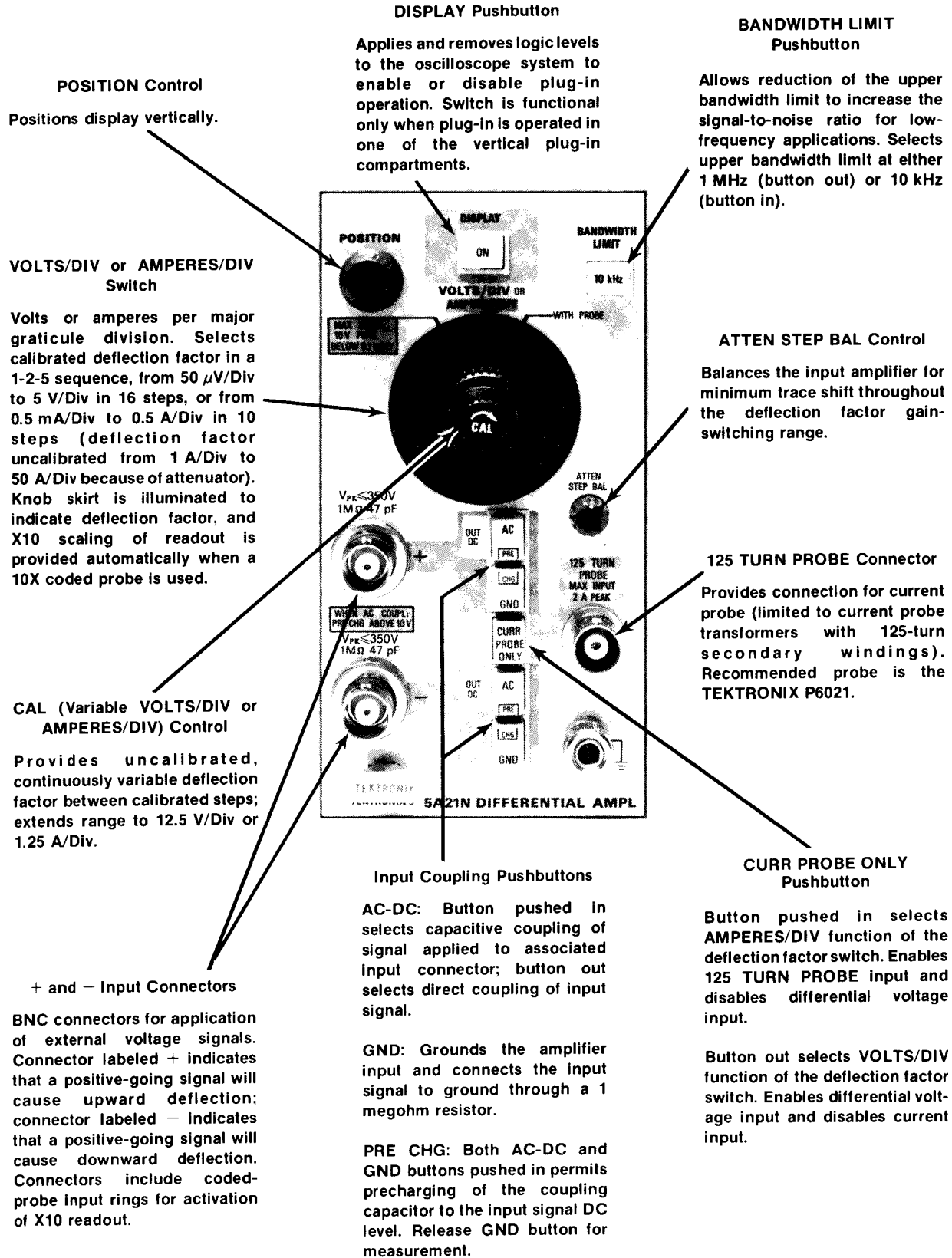

Fig. 2-1. Front-panel controls, connectors and indicators.

1139-02

| Fig. & Index No. | Tektronix Part No. | Serial/Model No. Eff Dscont | Qty | 1 | 2 | 3 | 4 | 5 | Name & Description | Mfr Code | Mfr Part Number |
|------------------|--------------------|-----------------------------|-----|---|---|---|---|---|--|----------|------------------|
| 1-1 | 366-0494-00 | | 1 | | | | | | KNOB:GRAY WITH SETSCREW | 80009 | 366-0494-00 |
| | 213-0153-00 | | 1 | | | | | | . SETSCREW:5-40 X 0.125,STL BK OXD,HEX SKT | 000CY | OBD |
| -2 | ----- | | - | | | | | | RESISTOR,VAR:(SEE R179 REPL) (ATTACHING PARTS) | | |
| -3 | 210-0583-00 | | 1 | | | | | | NUT,PLAIN,HEX:0.25-32 X 0.312 INCH,BRS | 73743 | 2X20317-402 |
| -4 | 210-0940-00 | | 1 | | | | | | WASHER,FLAT:0.25 ID X 0.375 INCH OD,STL - - - * - - - | 79807 | OBD |
| -5 | 131-0679-00 | B010100 B041688 | 2 | | | | | | CONNECTOR,RCPT,:BNC,MALE,3 CONTACT | 24931 | 28JR168-1 |
| | 131-0679-02 | B041689 | 2 | | | | | | CONNECTOR,RCPT,:BNC,MALE,3 CONTACT (ATTACHING PARTS) | 24931 | 28JR270-1 |
| | 220-0497-00 | XB041689 | 2 | | | | | | NUT,PLAIN,HEX.:0.5-28 X 0.562 INCH HEX,BRS | 73743 | OBD |
| | 210-1039-00 | XB041689 | 2 | | | | | | WASHER,LOCK:INT,0.521 ID X 0.625 INCH OD - - - * - - - | 24931 | OBD |
| | 129-0103-00 | | 1 | | | | | | POST,BDG,ELEC:ASSEMBLY | 80009 | 129-0103-00 |
| -6 | 129-0077-00 | | 1 | | | | | | . STUD,SHOULDERED:0.938 INCH LONG,BRASS | 80009 | 129-0077-00 |
| -7 | 200-0103-00 | | 1 | | | | | | . NUT,PLAIN,KNURL:0.25-28 X 0.375" OD,BRASS (ATTACHING PARTS) | 80009 | 200-0103-00 |
| -8 | 210-0583-00 | | 1 | | | | | | NUT,PLAIN,HEX:0.25-32 X 0.312 INCH,BRS | 73743 | 2X20317-402 |
| -9 | 210-0046-00 | | 1 | | | | | | WASHER,LOCK:0.261 ID,INTL,0.018 THK,BRS - - - * - - - | 78189 | 1214-05-00-0541C |
| -10 | 131-0955-00 | | 1 | | | | | | CONN,RCPT,ELEC:BNC,FEMALE | 13511 | 31-279 |
| | 131-2368-00 | XB084881 | 2 | | | | | | TERMINAL,STUD:0.601 L,INSULATED | 71279 | 5702432-020100 |
| -11 | 366-1036-01 | | 1 | | | | | | KNOB:GY,0.125 ID X 0.307 OD X 0.562 | 80009 | 366-1036-01 |
| -12 | 384-1065-00 | | 1 | | | | | | EXTENSION SHAFT:3.485 L X 0.125 OD AL | 80009 | 384-1065-00 |
| -13 | 376-0051-00 | B010100 B039999 | 1 | | | | | | CPLG,SHAFT,FLEX:0.127 ID X 0.375 ID DELRIN | 80009 | 376-0051-00 |
| | 376-0051-01 | B040000 | 1 | | | | | | CPLG,SHAFT,FLEX:0.127 ID X 0.375 OD | 80009 | 376-0051-01 |
| | 213-0022-00 | B010100 B039999 | 4 | | | | | | . SETSCREW:4-40 X 0.188 INCH,HEX SOC STL | 74445 | OBD |
| | 213-0178-00 | B040000 | 4 | | | | | | . SETSCREW:4-40 X 0.125 INCH,HEX,SOC STL | 74445 | OBD |
| | 354-0251-00 | | 2 | | | | | | . RING,COUPLING:0.251 ID X 0.375 INCH OD,AL | 80009 | 354-0251-00 |
| | 376-0049-01 | | 1 | | | | | | . CPLG,SHAFT,FLEX:0.127 ID X 0.375 OD,PP | 80009 | 376-0049-01 |
| -14 | 366-1286-00 | B010100 B039999 | 1 | | | | | | KNOB:SIL GY,0.5 X 0.2 X 0.375 | 80009 | 366-1286-00 |
| | 366-1286-03 | B040000 B069999 | 1 | | | | | | KNOB:SIL GY,0.5 X 0.2 X 0.375 | 80009 | 366-1286-03 |
| | 366-1690-00 | B070000 | 1 | | | | | | KNOB:SIL GY,0.53 X 0.23 X 1.059 | 80009 | 366-1690-00 |
| | 214-1840-00 | XB040000 B069999X | 1 | | | | | | PIN,KNOB SECRG:0.094 OD X 0.120 INCH LONG | 80009 | 214-1840-00 |
| -15 | 214-1513-00 | B010100 B039999 | 1 | | | | | | LCH,PL-IN RTNG:PLASTIC | 80009 | 214-1513-00 |
| | 214-1513-01 | B040000 B069999 | 1 | | | | | | LCH,PLUG-IN RET: | 80009 | 214-1513-01 |
| | 105-0719-00 | B070000 | 1 | | | | | | LATCH,RETAINING:PLUG-IN (ATTACHING PARTS) | 80009 | 105-0719-00 |
| -16 | 213-0254-00 | | 1 | | | | | | SCREW,TPG,TF:2-32 X 0.250,100 DEG,FLH - - - * - - - | 45722 | OBD |
| | 105-0718-01 | XB070000 | 1 | | | | | | BAR,LATCH RLSE: | 80009 | 105-0718-01 |
| -17 | 366-1257-15 | | 1 | | | | | | PUSH BUTTON:SIL GRAY,10KHZ | 80009 | 366-1257-15 |
| -18 | 384-1058-00 | | 1 | | | | | | EXTENSION SHAFT:8.157 INCH LONG | 80009 | 384-1058-00 |
| -19 | 426-0681-00 | | 7 | | | | | | FR,PUSH BUTTON:GRAY PLASTIC | 80009 | 426-0681-00 |
| -20 | 366-1257-11 | | 1 | | | | | | PUSH BUTTON:GRAY--AC PRE | 80009 | 366-1257-11 |
| -21 | 366-1257-12 | | 1 | | | | | | PUSH BUTTON:GRAY--CHG GND | 80009 | 366-1257-12 |
| -22 | 366-1257-13 | | 1 | | | | | | PUSH BUTTON:SIL GRAY,BI STABLE | 80009 | 366-1257-13 |
| -23 | 366-1257-11 | | 1 | | | | | | PUSH BUTTON:GRAY--AC PRE | 80009 | 366-1257-11 |
| -24 | 366-1257-12 | | 1 | | | | | | PUSH BUTTON:GRAY--CHG GND | 80009 | 366-1257-12 |
| -25 | 366-1257-14 | | 1 | | | | | | PUSH BUTTON:GRAY--ON | 80009 | 366-1257-14 |
| -26 | 384-1059-00 | | 1 | | | | | | EXTENSION SHAFT:6.58 INCH LONG | 80009 | 384-1059-00 |
| -27 | 136-0429-00 | | 2 | | | | | | RETAINER,LAMP:CAM SWITCH | 80009 | 136-0429-00 |
| -28 | 337-1430-00 | | 1 | | | | | | SHIELD,LIGHT:LAMP (ATTACHING PARTS) | 80009 | 337-1430-00 |
| -29 | 213-0254-00 | | 2 | | | | | | SCREW,TPG,TF:2-32 X 0.250,100 DEG,FLH - - - * - - - | 45722 | OBD |
| -30 | 366-1317-00 | | 1 | | | | | | KNOB:RED | 80009 | 366-1317-00 |
| | 213-0153-00 | | 1 | | | | | | . SETSCREW:5-40 X 0.125,STL BK OXD,HEX SKT | 000CY | OBD |
| -31 | 366-1295-00 | | 1 | | | | | | KNOB:GY,V/DIV,0.252 ID X 1.475 OD | 80009 | 366-1295-00 |
| | 213-0153-00 | | 2 | | | | | | . SETSCREW:5-40 X 0.125,STL BK OXD,HEX SKT | 000CY | OBD |
| -32 | 333-1388-00 | B010100 B084880 | 1 | | | | | | PANEL,FRONT: | 80009 | 333-1388-00 |
| | 333-1388-01 | B084881 | 1 | | | | | | PANEL,FRONT: | 80009 | 333-1388-01 |
| -33 | 386-1914-00 | B010100 B084880 | 1 | | | | | | SUBPANEL,FRONT: | 80009 | 386-1914-00 |
| | 386-1914-01 | B084881 | 1 | | | | | | SUBPANEL,FRONT: | 80009 | 386-1914-01 |

NOTE

About five minutes is sufficient time for warmup when using the 5A21N for short-term dc measurements. For long-term dc measurements using the more sensitive deflection factors, allow at least 15 minutes.

6. Adjust the Intensity control for normal viewing of the trace. The trace should appear near the graticule center.

7. Move the trace two divisions below the graticule centerline with the POSITION control.

8. Apply a 400 mV peak-to-peak signal (available at the oscilloscope Calibrator loop) through a test lead or 1X probe to the + input connector.

9. For dc-coupled, single-ended operation, release the GND button associated with the + Input Coupling switch. The display should be a square wave four divisions in amplitude, with the bottom of the display at the reference established in step 7. Rotate the Variable Volts/Div (CAL) control counterclockwise out of its detent position, observing reduction of the display. Return the CAL control to the detent position.

10. For ac-coupled, single-ended operation, reposition the display with the POSITION control to place the bottom of the display at the graticule centerline.

11. Push in the AC button and note that the display shifts downward about two divisions to its average level.

12. Disconnect the test lead or 1X probe from the Calibrator at the + input connector. Connect a dual-input cable to the + and – input connectors, then connect the test lead or 1X probe from the Calibrator to the dual-input cable.

13. For ac-coupled differential operation, set the – Input Coupling to AC (AC button in, GND button out). The calibrator signal is now coupled to both inputs as a common-mode signal. A straight line display should be observed, since the common-mode signal is being rejected.

Step Attenuator Balance Adjustment

If the ATTEN STEP BAL control is not properly adjusted, the display will shift vertically (due to an

imbalance in the amplifier) as the VOLTS/DIV switch is rotated throughout its range. The shift is more noticeable on the most sensitive positions.

1. With the instrument operating, ground both the + and – inputs (GND buttons pushed in), set the VOLTS/DIV switch to 5 V, and move the trace to graticule center with the position control.

2. Adjust the ATTEN STEP BAL control for minimum trace shift as the VOLTS/DIV switch is rotated throughout its range.

Gain Check

When the 5A21N is inserted into a plug-in compartment other than the one in which it was calibrated, the amplifier gain should be checked. If the amplifier gain needs to be adjusted, refer to qualified service personnel only.

DETAILED OPERATING INFORMATION**Applying Signals**

When measuring dc voltages, use the largest deflection factor (5 V/div) when first connecting the 5A21N to an unknown voltage source. If the deflection is too small to make the measurement, switch to a lower deflection factor. If the input stage is overdriven, a large amount of current might flow into the input and open the protective fuse.

Pre-Charging

When only the ac component of a signal having both ac and dc components is to be measured, use the Input Coupling switches (AC and GND pushbuttons) to take advantage of the pre-charging circuit incorporated in the unit. The pre-charging circuit permits charging the coupling capacitor to the dc source voltage when the AC and GND buttons are pressed in. The procedure for using this circuit is as follows:

a. Before connecting the 5A21N to a signal containing a dc component, push in the AC and GND buttons. Then connect the input to the circuit under test.

b. Wait about one second for the coupling capacitor to charge.

c. Remove the ground from the coupling capacitor (GND button out). The display will remain on-screen, and the ac component can be measured in the usual manner.

Replaceable Mechanical Parts—5A21N

CROSS INDEX—MFR. CODE NUMBER TO MANUFACTURER

| Mfr. Code | Manufacturer | Address | City, State, Zip |
|-----------|--|-------------------------|-----------------------------|
| 000CY | NORTHWEST FASTENER SALES, INC. | 7923 SW CIRRUS DRIVE | BEAVERTON, OR 97005 |
| 13511 | AMPHENOL CARDRE DIV., BUNKER RAMO CORP. | | LOS GATOS, CA 95030 |
| 24931 | SPECIALITY CONNECTOR CO., INC. | 2620 ENDRESS PLACE | GREENWOOD, IN 46142 |
| 45722 | USM CORP., PARKER-KALON FASTENER DIV. | | CAMPBELLSVILLE, KY 42718 |
| 55210 | GETTIG ENG. AND MFG. COMPANY | PO BOX 85, OFF ROUTE 45 | SPRING MILLS, PA 16875 |
| 71279 | CAMBRIDGE THERMIONIC CORP. | 445 CONCORD AVE. | CAMBRIDGE, MA 02138 |
| 71785 | TRW, CINCH CONNECTORS | 1501 MORSE AVENUE | ELK GROVE VILLAGE, IL 60007 |
| 73743 | FISCHER SPECIAL MFG. CO. | 446 MORGAN ST. | CINCINNATI, OH 45206 |
| 74445 | HOLO-KROME CO. | 31 BROOK ST. WEST | HARTFORD, CT 06110 |
| 77250 | PHEOLL MANUFACTURING CO., DIVISION OF ALLIED PRODUCTS CORP. | 5700 W. ROOSEVELT RD. | CHICAGO, IL 60650 |
| 78189 | ILLINOIS TOOL WORKS, INC. SHAKEPROOF DIVISION | ST. CHARLES ROAD | ELGIN, IL 60120 |
| 78471 | TILLEY MFG. CO. | 900 INDUSTRIAL RD. | SAN CARLOS, CA 94070 |
| 79136 | WALDES, KOHINOOR, INC. | 47-16 AUSTEL PLACE | LONG ISLAND CITY, NY 11101 |
| 79807 | WROUGHT WASHER MFG. CO. | 2100 S. O BAY ST. | MILWAUKEE, WI 53207 |
| 80009 | TEKTRONIX, INC. | P O BOX 500 | BEAVERTON, OR 97077 |
| 83385 | CENTRAL SCREW CO. | 2530 CRESCENT DR. | BROADVIEW, IL 60153 |
| 93907 | TEXTRON INC. CAMCAR DIV | 600 18TH AVE | ROCKFORD, IL 61101 |

Operating Instructions—5A21N

The above procedure should be followed whenever a signal having a different dc level is connected.

CAUTION

If the 5A21N input is connected to a large dc voltage source without using the pre-charge provision, the peak charging current (into a 0.1 μ F capacitor) will be limited only by the internal resistance of the signal source, and this source may be damaged.

Signal Input Connectors

When connecting signals to the + and – input connectors on the 5A21N, consider the method of coupling that will be used. Sometimes unshielded test leads can be used to connect the 5A21N to a signal source, particularly when a high level, low-frequency signal is monitored at a low impedance point. However, when any of these factors is missing, it becomes increasingly important to use shielded signal cables. In all cases, the signal-transporting leads should be kept as short as practical.

When making single-ended input measurement (conventional amplifier operation), be sure to establish a common ground connection between the device under test and the 5A21N. The shield of a coaxial cable is normally used for this purpose.

In some cases, differential measurements require no common ground connection¹ and therefore, are less susceptible to interference by ground-loop currents. Some problems with stray magnetic coupling into the signal-transporting leads can also be minimized by using a differential rather than a single-ended measurement. These considerations are discussed later in this section under Differential Operation.

It is always important to consider the signal source loading (and resulting change in the source operating characteristics) due to the signal-transporting leads and the input circuit of the 5A21N. The circuit at the input connectors can normally be represented by a 1 M Ω resistance to ground paralleled by about 47 pF. A few feet of shielded cable (20 to 40 pF per foot) may increase the parallel capacitance to 100 pF or more. In many cases, the effects of these resistive and capacitive loads may be too great and it may be desirable to minimize them through the use of an attenuator probe.

¹ The ac plus dc voltages on the test points (with respect to the chassis potential of the 5A21N) should be limited to the levels listed in Section 1 under Maximum Safe Input Voltage characteristics. Higher levels will degrade the common-mode rejection ratio and exceed the input voltage rating of the unit.

Attenuator probes not only decrease the resistive-capacitive loading of a signal source, but also extend the measurement range of the 5A21N to include substantially higher voltages. Passive attenuator probes having attenuation factors of 10X, 100X, and 1000X, as well as other special-purpose types, are available through your Tektronix Sales Engineer or Field Office.

Some measurement situations require a high resistance input to the 5A21N with very little source loading or signal attenuation. In such situations, a passive attenuator probe cannot be used. However, this problem may be solved by using a FET Probe or the high impedance input provision of the 5A21N.

Optional High Impedance Input (An Instrument Modification)

In the 50 mV through 50 μ V positions of the VOLTS/DIV switch, the input attenuator is not used and the 5A21N establishes the 1 M Ω input resistance. The 5A21N may be modified, allowing the instrument inputs to float, providing a very high input impedance. The signal source must then provide a dc path for input current.

NOTE

If a high impedance input is desired, refer the change to qualified service personnel. (Qualified service personnel: See this same subject heading in the servicing portion of this manual for details on making this input impedance change.) When the change is accomplished, the instrument front panel should be marked to reflect this change as a reminder to the user.

With this change, the input signal must be kept to relatively low amplitudes since the high impedance input feature is restricted to 50 mV/div to 50 μ V/div and dc coupling must be used.

NOTE

In the 0.1 V to 5 V range of the VOLTS/DIV switch, the high input impedance and the attenuation ratio is affected, causing the deflection factors in this range to be incorrect. To determine the deflection factor, check the deflection with an input signal of known amplitude.

The signal source impedance is an important factor because the 5A21N input current will produce a dc offset. For example, a 100 pA current through 10 m Ω produces a

REPLACEABLE MECHANICAL PARTS

PARTS ORDERING INFORMATION

Replacement parts are available from or through your local Tektronix, Inc. Field Office or representative.

Changes to Tektronix instruments are sometimes made to accommodate improved components as they become available, and to give you the benefit of the latest circuit improvements developed in our engineering department. It is therefore important, when ordering parts, to include the following information in your order: Part number, instrument type or number, serial number, and modification number if applicable.

If a part you have ordered has been replaced with a new or improved part, your local Tektronix, Inc. Field Office or representative will contact you concerning any change in part number.

Change information, if any, is located at the rear of this manual.

SPECIAL NOTES AND SYMBOLS

X000 Part first added at this serial number

00X Part removed after this serial number

FIGURE AND INDEX NUMBERS

Items in this section are referenced by figure and index numbers to the illustrations.

INDENTATION SYSTEM

This mechanical parts list is indented to indicate item relationships. Following is an example of the indentation system used in the description column.

```

1 2 3 4 5           Name & Description
Assembly and/or Component
Attaching parts for Assembly and/or Component
    --- * ---
Detail Part of Assembly and/or Component
Attaching parts for Detail Part
    --- * ---
Parts of Detail Part
Attaching parts for Parts of Detail Part
    --- * ---

```

Attaching Parts always appear in the same indentation as the item it mounts, while the detail parts are indented to the right. Indented items are part of, and included with, the next higher indentation. The separation symbol --- * --- indicates the end of attaching parts.

Attaching parts must be purchased separately, unless otherwise specified.

ITEM NAME

In the Parts List, an Item Name is separated from the description by a colon (:). Because of space limitations, an Item Name may sometimes appear as incomplete. For further Item Name identification, the U.S. Federal Cataloging Handbook H6-1 can be utilized where possible.

ABBREVIATIONS

| | | | | | | | |
|-------|--------------------|---------|-----------------------|----------|----------------------|---------|-----------------|
| " | INCH | ELCTRN | ELECTRON | IN | INCH | SE | SINGLE END |
| # | NUMBER SIZE | ELEC | ELECTRICAL | INCAND | INCANDESCENT | SECT | SECTION |
| ACTR | ACTUATOR | ELCTLT | ELECTROLYTIC | INSUL | INSULATOR | SEMICON | SEMICONDUCTOR |
| ADPTR | ADAPTER | ELEM | ELEMENT | INTL | INTERNAL | SHLD | SHIELD |
| ALIGN | ALIGNMENT | EPL | ELECTRICAL PARTS LIST | LPHLDR | LAMPHOLDER | SHLDR | SHOULDERED |
| AL | ALUMINUM | EQPT | EQUIPMENT | MACH | MACHINE | SKT | SOCKET |
| ASSEM | ASSEMBLED | EXT | EXTERNAL | MECH | MECHANICAL | SL | SLIDE |
| ASSY | ASSEMBLY | FIL | FILLISTER HEAD | MTG | MOUNTING | SLFLKG | SELF-LOCKING |
| ATTEN | ATTENUATOR | FLEX | FLEXIBLE | NIP | NIPPLE | SLVG | SLEEVING |
| AWG | AMERICAN WIRE GAGE | FLH | FLAT HEAD | NON WIRE | NOT WIRE WOUND | SPR | SPRING |
| BD | BOARD | FLTR | FILTER | OBD | ORDER BY DESCRIPTION | SQ | SQUARE |
| BRKT | BRACKET | FR | FRAME or FRONT | OD | OUTSIDE DIAMETER | SST | STAINLESS STEEL |
| BRS | BRASS | FSTNR | FASTENER | OVB | OVAL HEAD | STL | STEEL |
| BRZ | BRONZE | FT | FOOT | PH BRZ | PHOSPHOR BRONZE | SW | SWITCH |
| BSHG | BUSHING | FXD | FIXED | PL | PLAIN or PLATE | T | TUBE |
| CAB | CABINET | GSKT | GASKET | PLSTC | PLASTIC | TERM | TERMINAL |
| CAP | CAPACITOR | HDL | HANDLE | PN | PART NUMBER | THD | THREAD |
| CER | CERAMIC | HEX | HEXAGON | PNH | PAN HEAD | THK | THICK |
| CHAS | CHASSIS | HEX HD | HEXAGONAL HEAD | PWR | POWER | TNSN | TENSION |
| CKT | CIRCUIT | HEX SOC | HEXAGONAL SOCKET | RCPT | RECEPTACLE | TPG | TAPPING |
| COMP | COMPOSITION | HLCP | HELICAL COMPRESSION | RES | RESISTOR | TRH | TRUSS HEAD |
| CONN | CONNECTOR | HLEXT | HELICAL EXTENSION | RGD | RIGID | V | VOLTAGE |
| COV | COVER | HV | HIGH VOLTAGE | RLF | RELIEF | VAR | VARIABLE |
| CPLG | COUPLING | IC | INTEGRATED CIRCUIT | RTNR | RETAINER | W/ | WITH |
| CRT | CATHODE RAY TUBE | ID | INSIDE DIAMETER | SCH | SOCKET HEAD | WSHR | WASHER |
| DEG | DEGREE | IDENT | IDENTIFICATION | SCOPE | OSCILLOSCOPE | XFMR | TRANSFORMER |
| DWR | DRAWER | IMPLR | IMPELLER | SCR | SCREW | XSTR | TRANSISTOR |

1 mV offset, which may result in significant error where small voltages are of concern.

The high frequency response will also depend upon the signal source impedance, since various shunt capacitances of the source, the connecting cables and the 5A21N must charge and discharge through that impedance.

Display Polarity

Single-ended signals applied to the + input connector produce a display in phase with the input signal. Signals applied to the - input connector will be inverted.

A similar polarity relationship exists for differentially applied signals, but it pertains to the direction of voltage change at one input with respect to the other, rather than with respect to chassis potential.

Deflection Factor

The amount of trace deflection produced by a signal is determined by the signal amplitude, the attenuation factor (if any) of the probe, the setting of the VOLTS/DIV switch, and the setting of the CAL control. The calibrated deflection factors are indicated by the VOLTS/DIV switch only when the CAL control is rotated fully clockwise into the detent position.

The range of the CAL control is at least 2.5:1. It provides uncalibrated deflection factors covering the full range between the fixed settings of the VOLTS/DIV switch. The control can be set to extend the deflection factor to at least 12.5 V/div.

To reduce noise and obtain a more usable display when the VOLTS/DIV switch is set to the more sensitive positions, set the BANDWIDTH LIMIT switch to 10 kHz if this limit does not appreciably distort the desired features of the signal under observation. Figure 2-2 shows the improvement in a displayed 1 kHz signal when the BANDWIDTH LIMIT switch is used.

Optional Bandwidth Limiting Frequencies (An Instrument Modification)

In some applications, it may be desirable to change the upper bandwidth frequency limit to some other value than the two limits selectable at the front panel of the 5A21N (1 MHz and 10 kHz). The 10 kHz upper frequency limit (selected by the BANDWIDTH LIMIT push button) may be altered by changing one component in the instrument. Frequency limits other than 10 kHz that can be obtained with common component values are, for example: 300 kHz, 100 kHz, 30 kHz or 3 kHz.

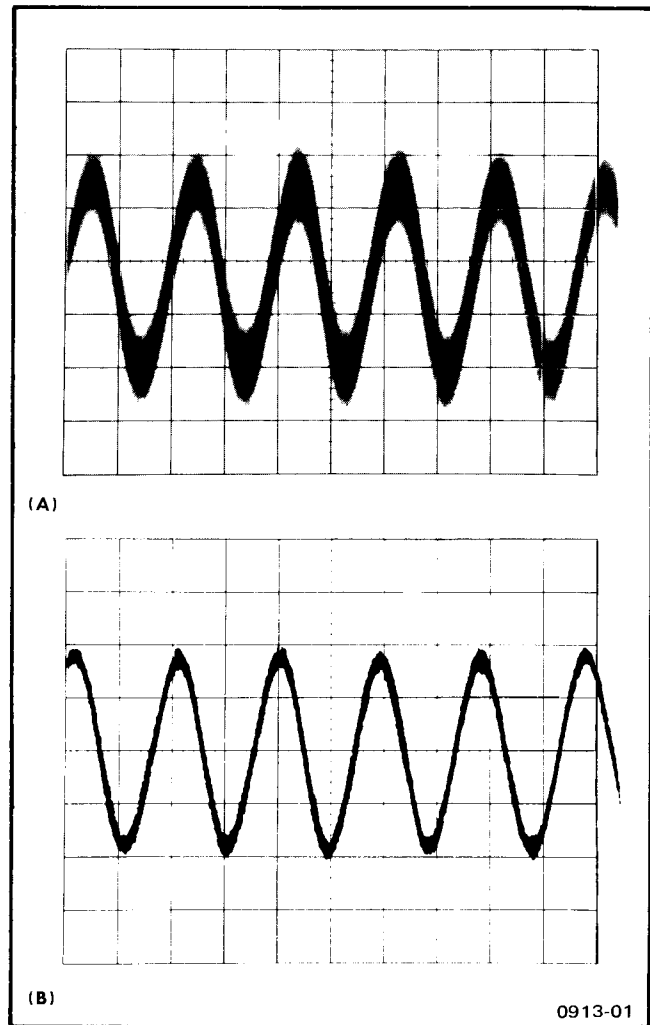

Fig. 2-2. Improving signal-to-noise ratio by setting bandwidth; (A) signal applied with the BANDWIDTH LIMIT switch set to 1 MHz, (B) same signal with the BANDWIDTH LIMIT switch set to 10 kHz.

NOTE

If a bandwidth limit frequency change is desired, refer the change to qualified service personnel. (Qualified service personnel: See this same subject heading in the servicing portion of this manual, for details on making this frequency change.) When a frequency change is accomplished, the instrument front panel should be marked to reflect this change as a reminder to the user.

Voltage Comparison Measurements

Some applications require deflection factors other than the fixed values provided by the VOLTS/DIV switch. One such application is comparison of signal amplitudes by ratio rather than by absolute voltage. To accomplish this, apply a reference signal to either input of the 5A21N, and

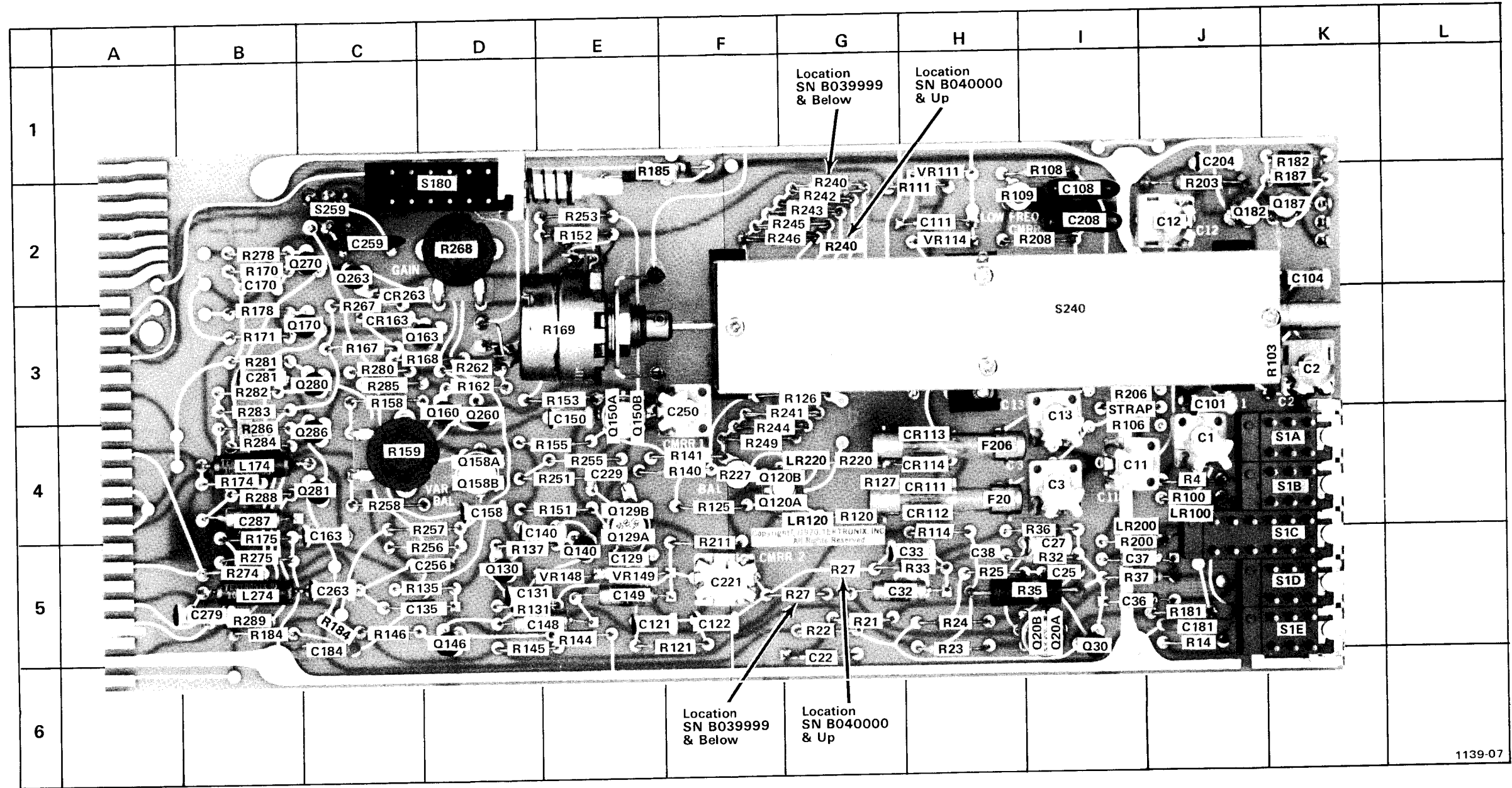

1139-07

*See Parts List for serial number ranges.

A1—Main Circuit Board (SN B069999 & Below)

†Located on back of board.

| CKT NO | GRID LOC | CKT NO | GRID LOC | CKT NO | GRID LOC | CKT NO | GRID LOC | CKT NO | GRID LOC | CKT NO | GRID LOC | CKT NO | GRID LOC | CKT NO | GRID LOC | CKT NO | GRID LOC | CKT NO | GRID LOC | CKT NO | GRID LOC | CKT NO | GRID LOC | CKT NO | GRID LOC | CKT NO | GRID LOC | | | |
|--------|----------|--------|----------|--------|----------|--------|----------|--------|----------|--------|----------|---------|----------|--------|----------|--------|----------|--------|----------|--------|----------|--------|----------|--------|----------|--------|----------|-------|----|--|
| C1 | J4 | C108 | I2 | C184* | C5 | CR111 | H4 | F20 | H4 | L174 | B4 | Q20A,B | I5 | Q187 | K2 | R27 | G5 | R125 | F4 | R158 | C3 | R184 | B5 | R240 | G2 | R267 | C3 | S1A | K4 | |
| C2 | K3 | C111 | H2 | C204 | J1 | CR112 | H4 | F206 | H4 | L274 | B5 | Q30 | I5 | Q260 | D3 | R32 | I5 | R126 | G3 | R159 | C4 | R185 | E1 | R241 | G3 | R268 | D2 | S1B | K4 | |
| C3 | I4 | C121 | E5 | C208 | I2 | CR113 | H4 | | | LR100* | J4 | Q120A,B | F4 | Q263 | C2 | R33 | H5 | R127† | G4 | R162 | D3 | R187 | K2 | R242 | G2 | R274 | B5 | S1C | K5 | |
| C11 | I4 | C122 | F5 | C221 | F5 | CR114 | H4 | | | LR120* | G4 | Q129A,B | E4 | Q270 | C2 | R35 | H5 | R131 | D5 | R167 | C3 | R200* | I5 | R243 | G2 | R275 | B5 | S1D | K5 | |
| C12 | J2 | C129 | E5 | C229 | E4 | CR163 | C3 | | | LR200* | I5 | Q130 | D5 | Q280 | C3 | R36 | I5 | R135 | D5 | R168 | D3 | R203 | J2 | R244 | F4 | R278 | B2 | S1E | K5 | |
| C13 | I4 | C131 | D5 | C250 | F3 | CR263 | C2 | | | LR220* | G4 | Q140 | E5 | Q281 | C4 | R37 | I5 | R137 | D5 | R169 | E3 | R206 | I3 | R245 | G2 | R280 | C3 | S180 | D2 | |
| C22 | G6 | C135 | D5 | C256 | D5 | | | | | | | Q146 | D5 | Q286 | C4 | R100* | J4 | R140 | F4 | R170 | B2 | R208 | I2 | R246 | G2 | R281 | B3 | S240 | I3 | |
| C25 | I5 | C140 | E4 | C259 | C2 | | | | | | | Q150A,B | E4 | | | R103 | K3 | R141 | F4 | R171 | B3 | R211 | F5 | R249 | F4 | R282 | B3 | S259† | C2 | |
| C27 | I5 | C148 | D5 | C263 | C5 | | | | | | | Q158A,B | D4 | R4 | J4 | R106 | I4 | R144 | E5 | R174 | B4 | R220 | G4 | R249 | F4 | R282 | B3 | | | |
| C32 | G5 | C149 | E5 | C279 | B5 | | | | | | | Q160 | D3 | R14 | J5 | R108 | I2 | R145 | D5 | R175 | B4 | R227 | F4 | R251 | E4 | R283 | B3 | STRAP | I4 | |
| C33 | H5 | C150 | E4 | C281 | B3 | | | | | | | Q163 | D3 | R21 | G5 | R109 | I2 | R146 | C5 | R178 | B3 | | | R253 | E2 | R284 | B4 | | | |
| C36 | I5 | C158 | D4 | C287 | B4 | | | | | | | Q170 | C3 | R22 | G5 | R111 | H2 | R151 | E4 | R181 | J5 | | | R255 | E4 | R285 | C3 | VR111 | H2 | |
| C37 | I5 | C163 | C4 | | | | | | | | | Q182* | J2 | R23 | H5 | R114 | H5 | R152 | E2 | R182* | K1 | | | R256 | D5 | R286 | B4 | VR114 | H2 | |
| C38* | H5 | C170 | B2 | | | | | | | | | | | R24 | H5 | R120 | G4 | R153 | E3 | | | | | R257 | D4 | R288 | B4 | VR148 | E5 | |
| C101 | J3 | C181 | J5 | | | | | | | | | | | R25 | H5 | R121 | F5 | R155 | E4 | | | | | R258 | C4 | R289 | B5 | VR149 | E5 | |
| C104 | K2 | | | | | | | | | | | | | | | | | | | | | | | | | | | | | |

Operating Instructions—5A21N

set the VOLTS/DIV switch and CAL control so that the reference display covers the desired number of graticule divisions. Do not change this setting of the CAL control throughout the subsequent comparisons. The settings of the VOLTS/DIV switch can be changed, however, to accommodate large ratios. In doing so, regard the numbers which designate the switch positions as ratio factors rather than voltages.

Differential Operation

Single-ended measurements often yield unsatisfactory results because of interferences resulting from ground-loop currents between the 5A21N and the device under test. In other cases, it may be desirable to eliminate a dc voltage by means other than the use of a dc-blocking capacitor, which could limit the low-frequency response.

These limitations of single-ended measurements are effectively eliminated using differential measurements. Differential measurements are made by connecting each input (+ input and - input) to selected points in the test circuit. Since the chassis of the 5A21N need not be connected in any way to the test circuit, there are few limitations to the selection of these test points. In any case, do not exceed the maximum safe input voltages listed in Section 1, Table 1-1.

Both Input Coupling switches should be set to the same position, AC or DC, depending on the method of signal coupling required.

Only the voltage difference between two signals is amplified and displayed in differential measurements, while the common-mode signals (common in amplitude, frequency, and phase) are rejected. See Fig. 2-3.

The ability of the 5A21N to reject common-mode signals is indicated by the common-mode rejection ratio (CMRR). CMRR is at least 100,000:1 at the input connectors for the lower deflection factors (50 $\mu\text{V}/\text{div}$ and 100 $\mu\text{V}/\text{div}$) when signals between dc and 30 kHz are dc coupled to the inputs. To illustrate this characteristic, assume that a single-ended input signal consists of an unwanted 60 Hz signal at 1 V peak-to-peak, plus a desired signal at 1 mV peak-to-peak. If an attempt is made to display the described signal (single-ended measurement) at .2 mV/div, the 60 Hz signal will produce a deflection equivalent to 5000 divisions and the 1 mV signal will be lost.

If the same 1 mV signal is measured differentially with the 60 Hz signal common to both inputs, no more than one part in 100,000 of the common-mode signal will appear in the display. The desired signal will produce a display of 5

divisions, with not more than 0.1 division of display produced by the common-mode signal (CMRR not specified when residual display is 0.1 division or less).

There are a number of factors which can degrade common-mode rejection. The principal requirement for maximum rejection is for the common-mode signal to arrive at the input FET gates in precisely the same form. A difference of only 0.01% in the attenuation factors of the input attenuators may reduce the rejection ratio to 10,000:1. Likewise, any difference in source impedance at the two points in the source under test will degrade the rejection ratio. Attenuator probes which do not have adjustable resistance and capacitance may reduce the rejection ratio to 100:1 or less.

Outside influences such as magnetic fields can also degrade the performance, particularly when low level signals are involved. Magnetic interference may be minimized by using identical signal-transporting leads to the two inputs and twisting the two leads together over as much of their length as possible.

Voltage Probes

In general, probes offer the most convenient means of connecting a signal to the input of the 5A21N. Tektronix probes are shielded to prevent pickup of electrostatic interference. A 10X attenuator probe offers a high input impedance and allows the circuit under test to perform very close to normal operating conditions. See your Tektronix, Inc., catalog for characteristics and compatibility of probes for use with this system.

Differential Measurement. The following adjustment procedure is recommended when preparing to use two TEKTRONIX P6055 probes for differential measurement.

a. Connect one probe for dc-coupled single-ended input to the + input connector. Obtain a triggered display of an appropriate square wave, such as that from a calibrator or square-wave generator.

Adjust the probe dc calibration control for correct deflection sensitivity, then compensate the probe square-wave response using the ac fine comp adjust and the coarse comp adjust if necessary.

b. Connect a second probe for dc-coupled operation to the - input connector. Apply the square wave to both probes at 100 V peak-to-peak. Free run the sweep and adjust the dc calibration of the second probe for maximum low frequency cancellation (minimum signal amplitude, or elimination of the two-trace appearance).

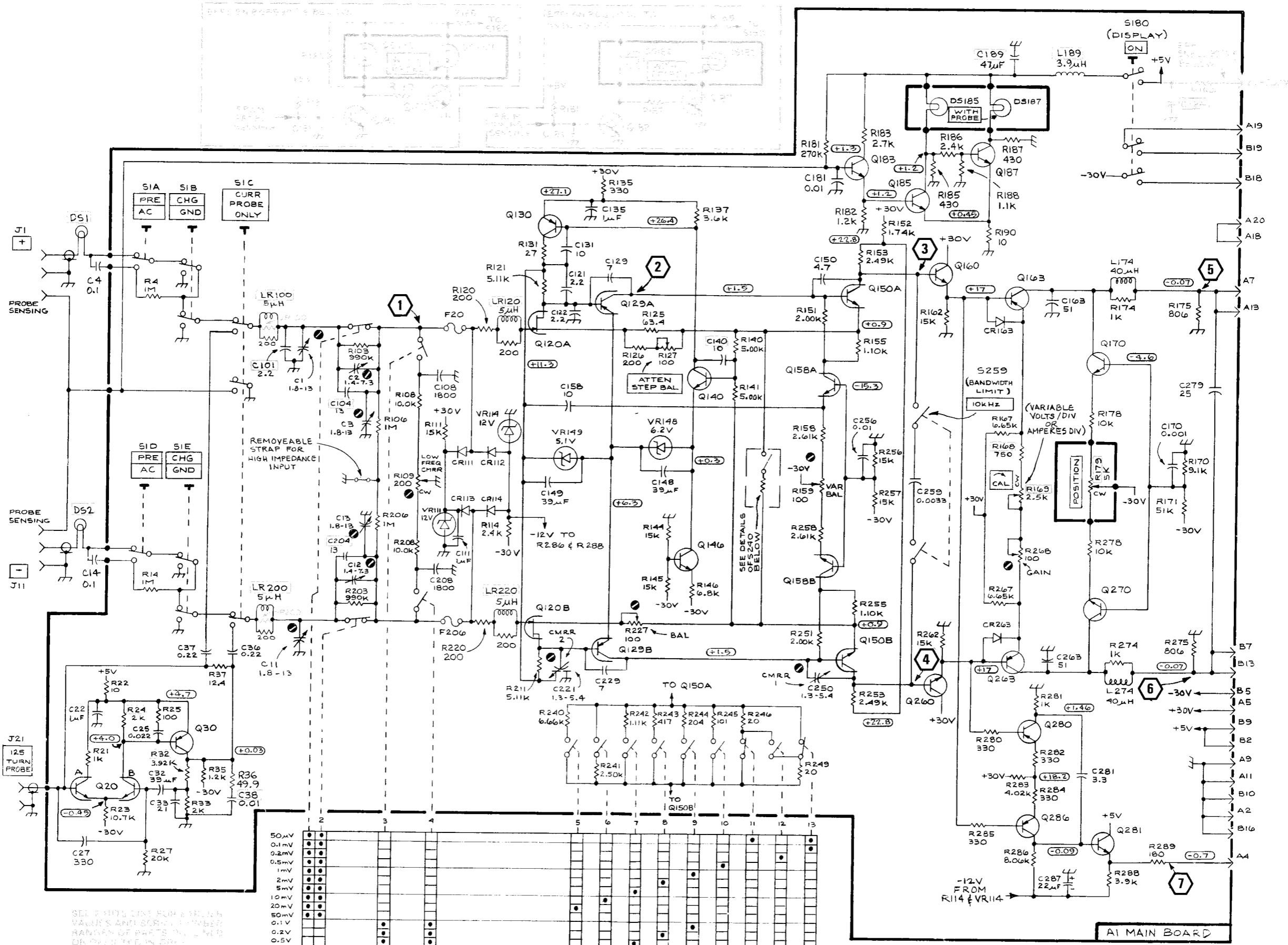

SEE PARTS LIST FOR ALL PART VALUES AND SERIAL NUMBER BANDS OF PARTS IN CIRCLED OR OVAL SYMBOLS.

INDICATES SWITCH CLOSED

| | | | | | | | | | | | | |
|-------|--|--|--|--|--|--|--|--|--|--|--|--|
| 50μV | | | | | | | | | | | | |
| 0.1mV | | | | | | | | | | | | |
| 0.2mV | | | | | | | | | | | | |
| 0.5mV | | | | | | | | | | | | |
| 1mV | | | | | | | | | | | | |
| 2mV | | | | | | | | | | | | |
| 5mV | | | | | | | | | | | | |
| 10mV | | | | | | | | | | | | |
| 20mV | | | | | | | | | | | | |
| 50mV | | | | | | | | | | | | |
| 0.1V | | | | | | | | | | | | |
| 0.2V | | | | | | | | | | | | |
| 0.5V | | | | | | | | | | | | |
| 1V | | | | | | | | | | | | |
| 2V | | | | | | | | | | | | |
| 5V | | | | | | | | | | | | |

5A21N

(SHOWN IN 50μV POSITION) S240

VOLTS/DIV OR AMPERES/DIV

1139-09 REV JUN 1982

DIFFERENTIAL AMPLIFIER

1071 EEB

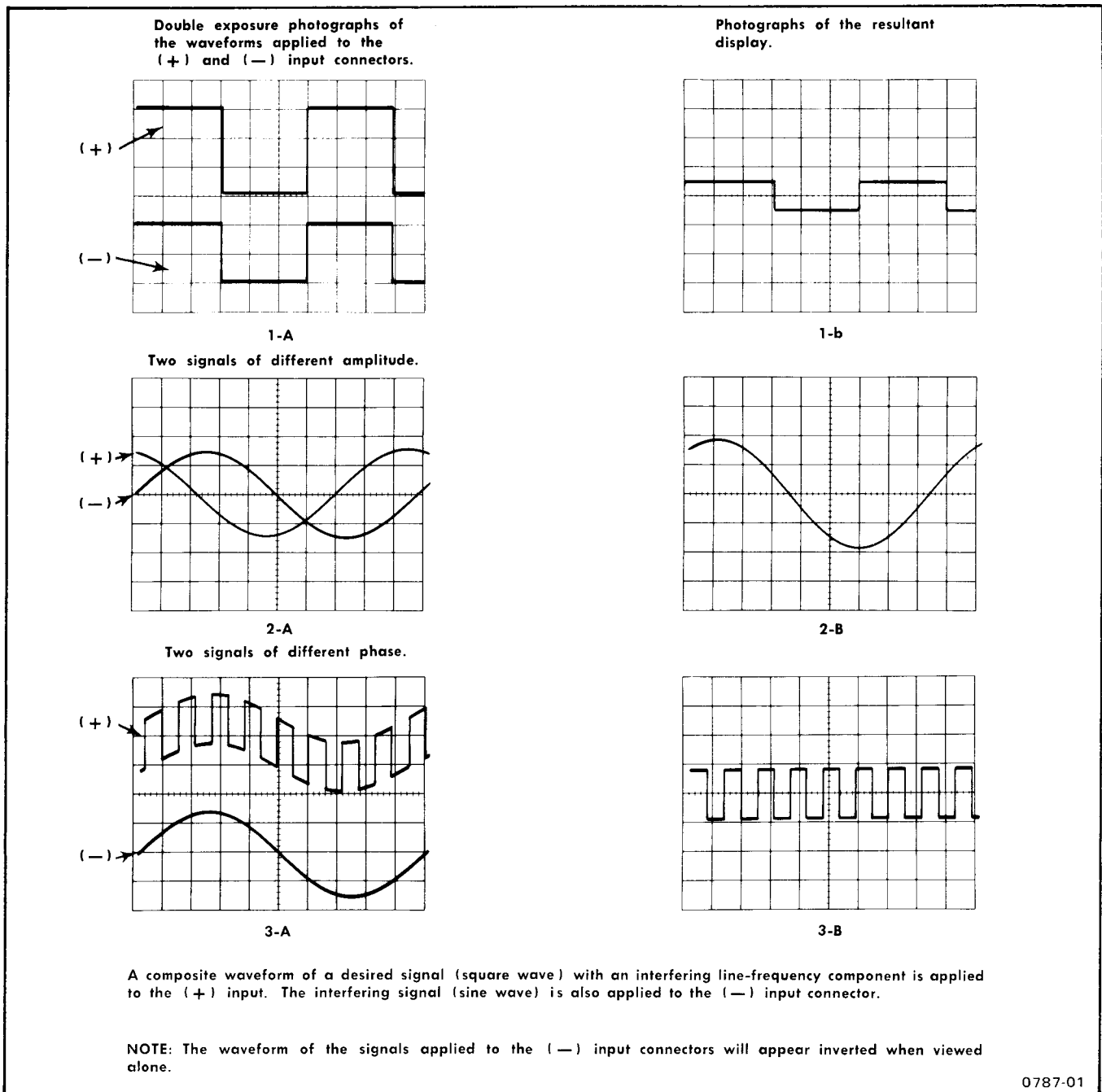

Fig. 2-3. Three examples of differential applications.

c. Adjust the ac fine comp and ac coarse comp, if necessary, of the second probe to minimize the amplitude of the differential pulses on the displayed trace.

d. The preceding procedure matches the probes for use at any sensitivity which employs the particular 5A21N input attenuator (1X or 100X) used in steps b and c. When it is necessary to use the other input attenuator, steps b and c should be repeated for that attenuator.

e. When examining a small differential signal in the presence of relatively large common-mode components, fine adjustment of probe CMRR may be made by temporarily connecting both probes to either of the two signal sources.

f. Movement of the probes should be kept to a minimum after the adjustment.

Operating Instructions—5A21N

Coded Probes. The 5A21N is designed for compatibility with coded probes, such as the TEKTRONIX P6060 or P6062B 1X/10X Passive Probe. The + and – input connectors have an outer ring to which the coding pin on the probe connector makes contact. This type of probe allows the vertical deflection factor indicated by the readout to correspond with the actual voltage at the probe tip, eliminating the need to consider the attenuation factor when measuring the signal amplitude on the graticule scale.

Attenuation on the P6062B probe is selected by a sliding switch on the probe body. 1X or 10X attenuation may be selected, allowing the user to switch in or out a decade of sensitivity without returning to the 5A21N VOLTS/DIV switch. This dual-attenuation feature is valuable for allowing the use of full 5A21N sensitivity in 1X attenuation, and for evaluating the effects of probe loading when switching from 1X to 10X attenuation. Input resistance for 1X attenuation is 1 M Ω ; for 10X, 10 M Ω .

Probe compensation is obtained at the bnc connector of the probe (see probe manual for details on probe compensation).

Current Probes

The current probe input is limited to current probe transformers with 125-turn secondary windings and the P6021 AC Current Probe is the recommended probe to use with the 5A21N (provided with Option 01). No special preparation of the 5A21N is required. No termination or external amplifier is required to use the P6021 Probe with the 5A21N. Connect the probe to the 125 TURN PROBE connector and select the CURR PROBE ONLY mode of instrument operation. Refer to the current probe manual for probe details.

The 5A21N calibrated current deflection range is from 0.5 mA/div to 0.5 A/div in 10 steps. Deflection factor is uncalibrated from 1 A/div to 50 A/div because of attenuator switching.

VOLTAGE AND WAVEFORM CONDITIONS

WARNING

Dangerous potentials exist at several points throughout this instrument. When the instrument is operated with the covers removed, do not touch exposed connections or components. Some transistors have voltages present on their cases. Disconnect the power source before replacing parts.

RECOMMENDED TEST EQUIPMENT

| Item | Specifications | Recommended Type |
|--|---|---|
| Test oscilloscope system | Deflection factor, 1 mV to 50 V/div; input impedance, 1 megohm; frequency response, dc to 2 MHz. Probe: 10X attenuation probe compatible with vertical input. | TEKTRONIX 5110, 5A13N, 5B10N oscilloscope system or equiv. Use a TEKTRONIX P6060 or P6062B Probe. |
| Voltmeter (Non-loading digital multimeter) | Range, 0 to 250 V; input impedance, 10 megohms. | TEKTRONIX DM 501A Option 02 Multimeter with power module. |
| Plug-in extender | Allows Tektronix 7000-series plug-in operation extended from the mainframe. | Tektronix 067-0645-03 Calibration Fixture. |

Voltage Conditions

The 5A21N Differential Amplifier unit is connected to the left vertical compartment of the oscilloscope mainframe using a plug-in extender. No signal is applied to the 5A21N for voltage measurements. Voltmeter common is connected to chassis ground.

Waveform Conditions

5A21N UNDER TEST. The 5A21N Differential Amplifier unit is connected to the left vertical compartment of an oscilloscope mainframe (separate mainframe from the test oscilloscope) using a plug-in extender. The mainframe Calibrator output signal is connected to the 5A21N + input (set + input coupling to DC, - input coupling to GND, and VOLTS/DIV for a two-division display). Set the time-base unit for internal auto-trigger, two millisecond/division sweep rate.

TEST OSCILLOSCOPE. Set the test oscilloscope triggering for auto mode with ac coupling from the internal source and set vertical input coupling to ac. Connect a 10X probe to the vertical input. Position the display as necessary.

NOTE

The waveforms shown are actual waveform photographs taken with a TEKTRONIX Oscilloscope Camera System and Projected Graticule. Vertical deflection factor shown on the waveform is the actual deflection factor from the probe tip. Voltages and waveforms on the diagrams are not absolute and may vary between instruments because of component tolerances, internal calibration, or front-panel settings. Readouts are simulated in larger-than-normal type.

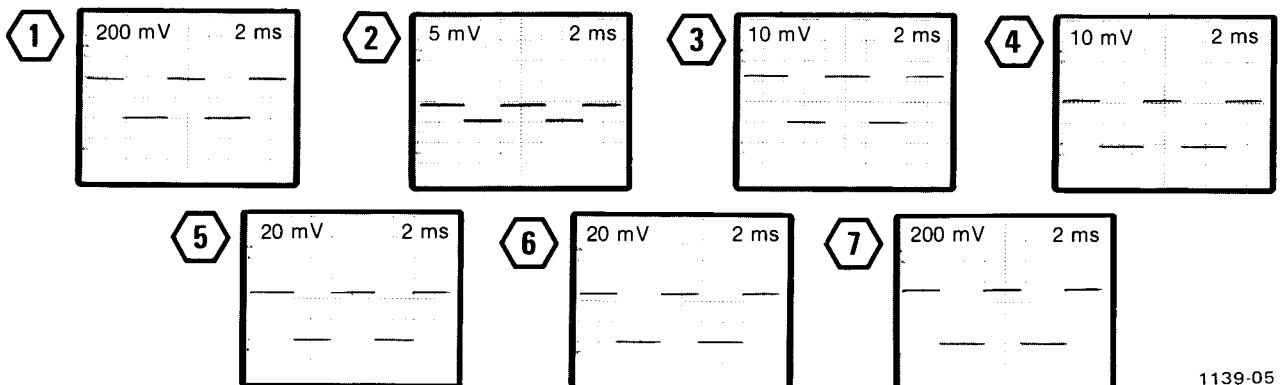

WARNING

THE FOLLOWING SERVICING INSTRUCTIONS ARE FOR USE BY QUALIFIED PERSONNEL ONLY. TO AVOID PERSONAL INJURY, DO NOT PERFORM ANY SERVICING OTHER THAN THAT CONTAINED IN OPERATING INSTRUCTIONS UNLESS YOU ARE QUALIFIED TO DO SO. REFER TO OPERATORS SAFETY SUMMARY AND SERVICE SAFETY SUMMARY PRIOR TO PERFORMING ANY SERVICE.



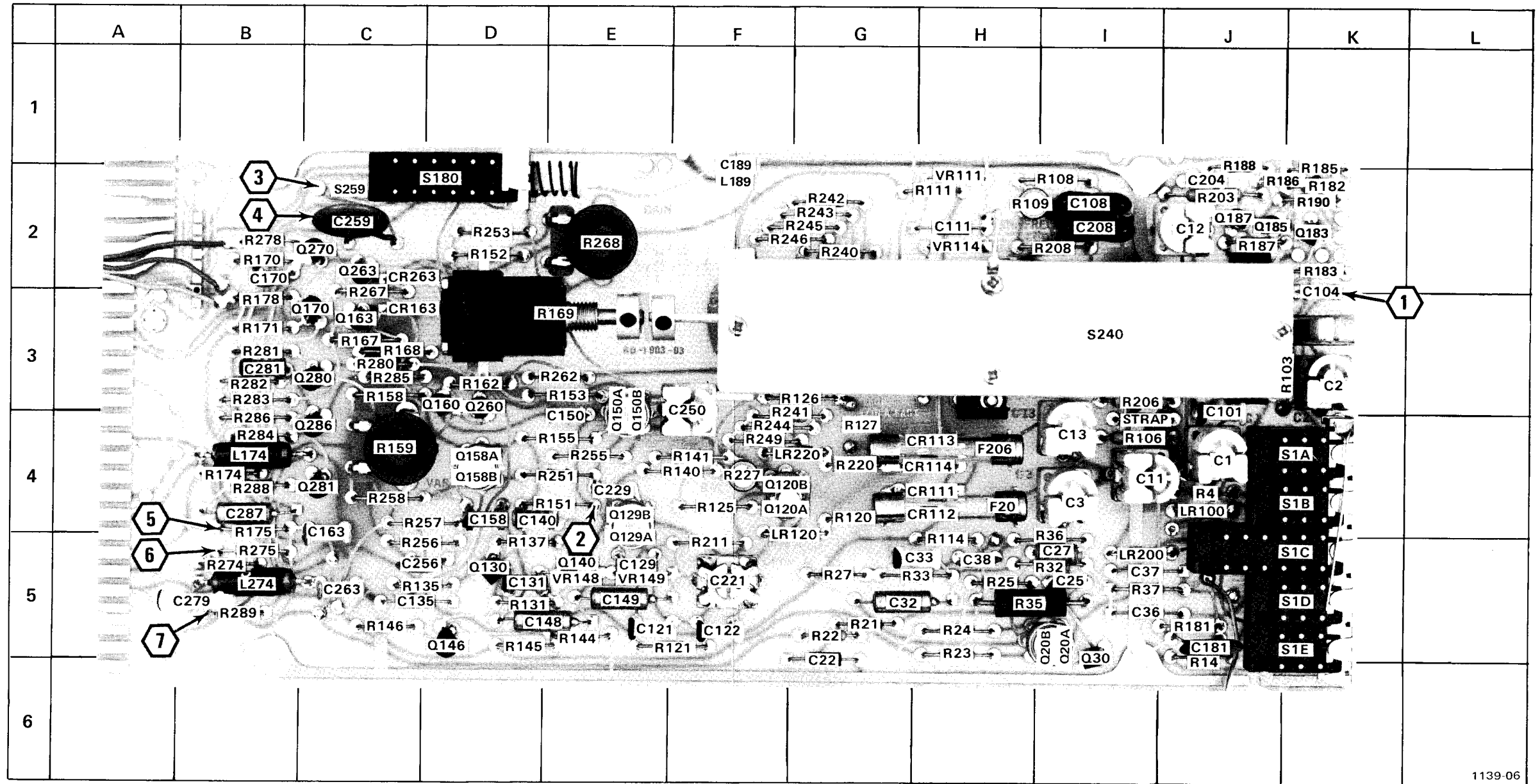

*See Parts List for serial number ranges.

1139-06

A1—Main Circuit Board (SN B070000 & up)

(Component Locations for SN B069999 & below is located on back of schematic diagram).

† Located on back of board.

| CKT NO | GRID LOC | CKT NO | GRID LOC | CKT NO | GRID LOC | CKT NO | GRID LOC | CKT NO | GRID LOC | CKT NO | GRID LOC | CKT NO | GRID LOC | CKT NO | GRID LOC | CKT NO | GRID LOC | CKT NO | GRID LOC | CKT NO | GRID LOC | CKT NO | GRID LOC | CKT NO | GRID LOC | CKT NO | GRID LOC | | | |
|--------|----------|--------|----------|--------|----------|--------|----------|--------|----------|--------|----------|---------|----------|--------|----------|--------|----------|--------|----------|--------|----------|--------|----------|--------|----------|--------|----------|-------|----|--|
| C1 | J4 | C108 | I2 | C204 | J2 | CR111 | H4 | F20 | H4 | L174 | B4 | Q20A,B | I5 | Q187 | J2 | R27 | G5 | R125 | F4 | R158 | C3 | R185 | K1 | R240 | G2 | R267 | C3 | S1A | K4 | |
| C2 | K3 | C111 | H2 | C208 | I2 | CR112 | H4 | F206 | H4 | L189† | F2 | Q30 | I5 | Q260 | D3 | R32 | I5 | R126 | G3 | R159 | C4 | R186 | J2 | R241 | G3 | R268 | E2 | S1B | K4 | |
| C3 | I4 | C121 | E5 | C221 | F5 | CR113 | H4 | | | L274 | B5 | Q120A,B | F4 | Q263 | C2 | R33 | H5 | R127† | G4 | R162 | D3 | R187 | J2 | R242 | G2 | R274 | B5 | S1C | K5 | |
| C11 | I4 | C122 | F5 | C229 | E4 | CR114 | H4 | | | LR100 | J4 | Q129A,B | E4 | Q270 | C2 | R35 | H5 | R131 | D5 | R167 | C3 | R188 | J1 | R243 | G2 | R275 | B5 | S1D | K5 | |
| C12 | J2 | C129 | E5 | C250 | F3 | CR163 | C3 | | | LR120 | G4 | Q130 | D5 | Q280 | C3 | R36 | I4 | R135 | D5 | R168 | D3 | R190 | K2 | R244 | F4 | R278 | B2 | S1E | K5 | |
| C13 | I4 | C131 | D5 | C256 | D5 | CR263 | C2 | | | LR200 | I5 | Q140 | E5 | Q281 | C4 | R37 | I5 | R137 | D5 | R169 | E3 | R203 | J2 | R245 | G2 | R280 | C3 | S180 | D2 | |
| C22 | G5 | C135 | C5 | C259 | C2 | | | | | LR220 | G4 | Q146 | D5 | Q286 | C4 | R103 | K3 | R140 | F4 | R170 | B2 | R206 | I3 | R246 | G2 | R281 | B3 | S240 | I3 | |
| C25 | I5 | C140 | D4 | C263 | C5 | | | | | | | Q150A,B | E3 | | | R106 | I4 | R141 | F4 | R171 | B3 | R208 | I2 | R249 | F4 | R282 | B3 | S259† | C2 | |
| C27 | I5 | C148 | E5 | C279 | B5 | | | | | | | Q158A,B | D4 | R4 | J4 | R108 | I2 | R144 | E5 | R174 | B4 | R211 | F5 | R251 | E4 | R283 | B3 | | | |
| C32 | G5 | C149 | E5 | C281 | B3 | | | | | | | Q160 | D3 | R14 | J5 | R109 | H2 | R145 | D5 | R175 | B4 | R220 | G4 | R253 | D2 | R284 | B4 | STRAP | I4 | |
| C33 | H5 | C150 | E3 | C287 | B4 | | | | | | | Q163 | C3 | R21 | G5 | R111 | H2 | R146 | C5 | R178 | B3 | R227 | F4 | R255 | E4 | R285 | C3 | VR111 | H2 | |
| C36 | I5 | C158 | D4 | | | | | | | | | Q170 | C3 | R22 | G5 | R114 | H5 | R151 | E4 | R181 | J5 | | | R256 | D5 | R286 | B4 | VR114 | H2 | |
| C37 | I5 | C163 | C4 | | | | | | | | | Q183 | K2 | R23 | H5 | R120 | G4 | R152 | D2 | R182 | K2 | | | R257 | D4 | R288 | B4 | VR148 | E5 | |
| C38 | H5 | C170 | B2 | | | | | | | | | Q185 | J2 | R24 | H5 | R121 | F5 | R153 | E3 | R183 | K2 | | | R258 | C4 | R289 | B5 | VR149 | E5 | |
| C101 | J3 | C181 | J5 | | | | | | | | | | | R25 | H5 | | | R155 | E4 | | | | | | | | | | | |
| C104 | K2 | C189 | F2 | | | | | | | | | | | | | | | | | | | | | | | | | | | |

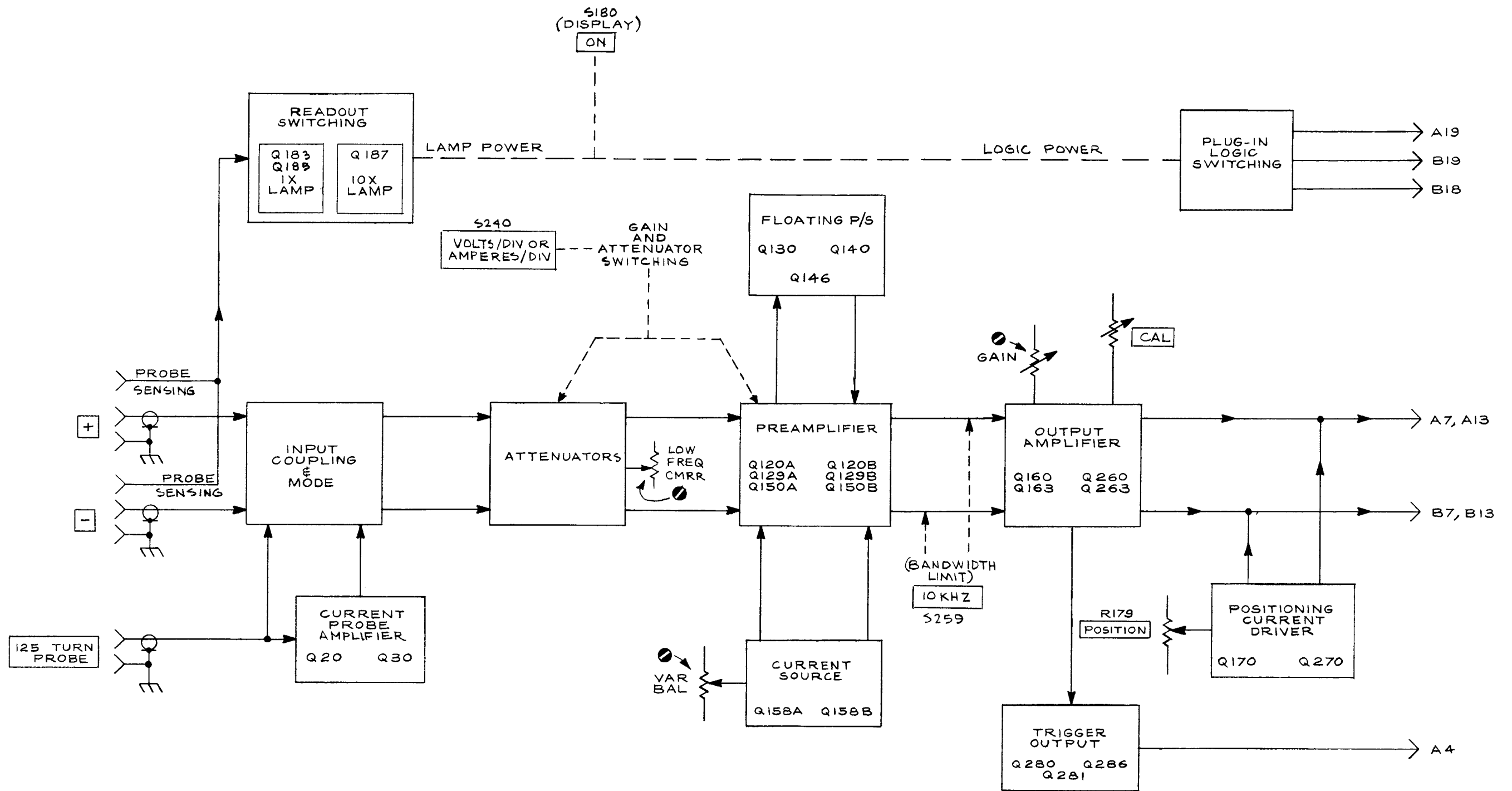

THEORY OF OPERATION

INTRODUCTION

The entire content of this manual may be used as servicing information. Refer to the Table Of Contents for a detailed listing of all information contained in this manual.

This section of the manual describes the circuitry used in the 5A21N Differential Amplifier. The description begins with a block diagram discussion, then continues with a detailed operation discussion that shows the relationships between the stages in each major circuit. Schematics of all circuits are given in Section 8 (Diagrams and Circuit Board Illustrations). Refer to these schematics throughout the following discussions for specific electrical values and relationships.

BLOCK DIAGRAM

The following discussion is provided to aid in understanding the overall concept of the 5A21N before the individual circuits are discussed in detail. A basic block diagram is shown in Section 8. Each block represents a major circuit in the instrument. Only the basic interconnections between the blocks are shown on the block diagram.

When the DISPLAY ON button is pressed, a signal is applied to the oscilloscope to enable 5A21N operation (switch function is limited to operation in a vertical compartment) and the front-panel readout lamp illuminates to indicate the ON mode.

Voltage signals applied to the + and - input connectors can be passed directly to the attenuators (dc coupled) or they can be capacitively (ac) coupled to block the dc component of the signal. The GND switch disconnects all input signals and applies a reference ground to the preamplifier input; for ac-coupled signals applied to the instrument in the GND position, the coupling capacitor is allowed to pre-charge to the dc level of the signal, preventing a damaging current surge when the ground is removed.

A current signal applied via the P6021 Current Probe is ac-coupled to the preamplifier + input when the CURR PROBE ONLY button is pressed. The signal is also applied to the current probe amplifier which compensates the probe characteristics. The compensated signal is then ac-coupled to the preamplifier + input.

The input attenuators are frequency-compensated voltage dividers. 1X attenuation is provided for positions 50 μ V to 50 mV of the VOLTS/DIV switch, and 100X attenuation is provided for positions 0.1 V to 5 V. Balance to a low-frequency common-mode signal between the attenuators of the two inputs is set by adjustment of the Low Freq CMRR potentiometer.

From the input attenuators, the signal is passed directly to the preamplifier. The inputs to the preamplifier are fuse- and diode-protected. The preamplifier consists of two identical operational amplifiers connected in a differential configuration. Common-mode signals between ground and the two inputs are rejected, due to a bootstrapped floating power supply that moves with the common-mode signal to maintain constant operating characteristics of the active devices. The difference between the two inputs is amplified. The VOLTS/DIV switch changes the value of the common source/emitter resistor between the two sides, thus changing the gain for various deflection factors. The output of the preamplifier stage is a push-pull signal, opposite in polarity to that applied to the input.

The BANDWIDTH LIMIT 10 kHz switch places a capacitor across the two output lines to reduce the bandwidth, and thus limit the noise referred to the input. The signal is then passed through an emitter-follower isolation stage to the output amplifier.

The output amplifier is operated push-pull, presenting a signal to the output terminals of the same polarity as that applied to the preamplifier input. Emitter degeneration produced by the CAL and Gain controls provides a means of varying the gain of the 5A21N. A positioning-current driver is connected to the output lines to alter the quiescent crt beam position.

A triggering signal is tapped from the emitter-follower isolation stage, amplified, and made available to an associated time-base plug-in unit. Triggering signal amplitude is about 0.25 V per displayed division.

DETAILED CIRCUIT OPERATION

Plug-In Logic

When DISPLAY ON button S180 is pressed, power is applied to the electronic switching circuit in the oscilloscope to enable plug-in operation. Power is applied to

Theory of Operation—5A21N

illuminate the front-panel knob-skirt readout lamp, indicating the ON mode.

Input Coupling

Signals applied to the front-panel + and – input connectors may be capacitive coupled, direct coupled, or internally disconnected. Input coupling is selected by means of two pushbutton switches at each input, S1A and S1B for the + input and S1D and S1E for the – input.

Assuming that a signal is applied to the + input, the applied signal is passed directly to the attenuators, when both buttons are out. When the AC button is pressed, C4 is placed in the circuit to couple signals of about 2 Hz (–3 dB point) or higher to the attenuator. This capacitor blocks any dc component of the signal. When the GND button is pressed, a ground reference is provided to the input of the amplifier without the need to remove the applied signal from the input connector.

NOTE

When dc levels above 10 V are to be blocked by ac coupling, both the AC and GND buttons should be pressed in (PRE CHG) while input connections are made or broken, or when voltage levels are changed. This will allow the coupling capacitor to charge without blowing the input fuses or overdriving the amplifier.

Current Probe Amplifier

The current probe amplifier, made up of Q20, Q30 and their associated passive circuitry, is an operational amplifier which compensates for the probe characteristics. When the CURR PROBE ONLY button is pressed, S1C disconnects the + and – voltage inputs and connects the current probe signal to the input attenuators. Probe signal is applied from J21 to the base of Q20A, and at the same time, it is applied via C37 to the positive side of the preamplifier input. The compensated signal is developed at the collector of Q30 and applied via C36 to the negative side of the preamplifier input.

Input Attenuators

The input attenuators are frequency-compensated voltage dividers that provide 100X attenuation in positions 0.1 to 5 of the VOLTS/DIV switch. At dc and for low-frequency signals, the dividers are essentially resistive (attenuation ratio determined by the resistance ratio). Balance to a low-frequency common-mode signal between the attenuators of the two inputs is set by adjustment of R109, Low Freq CMRR. At higher frequencies, the capacitive reactance becomes effective and the attenuation ratio is determined by the impedance ratio.

In addition to providing constant 100X attenuation at all frequencies within the bandwidth capabilities of the instrument, the input attenuators maintain a constant input RC characteristic (1 mΩ paralleled by about 47 pF) for settings 0.1 to 5 of the VOLTS/DIV switch.

Input Protection

Input protection consists of fuses F20, F206 and diodes CR111, CR112, CR113, and CR114. If the signal should reach a level sufficient to forward bias one of the protection diodes (a potential greater than about 12.5 V), current will be conducted through that diode, protecting the input FET's. If that current should exceed the I²T rating of the fuse, the protective fuse(s) will open. If the signal source is not able to supply enough current to open the fuse, damage to the signal source may result.

Preamplifier Stage

The preamplifier consists of two identical operational amplifiers, connected in a differential configuration. Fig. 3-1 shows a detailed block diagram of the Preamplifier.

The operational amplifiers are composed of Q120A, Q129A and Q150A on one side, and Q120B, Q129B and Q150B on the other side. Q120A and Q120B provide a voltage follower input to output transistors Q150A and Q150B. Total gain of the stage is determined by the resistance between the two sides of the amplifier, and R153 and R253 (the signal current path in Fig. 3-1).

Quiescently, the two sides of the amplifier are balanced so that there is no current through R240. When a differential signal is applied to the gates of Q120A and Q120B, the signal current is developed through the parallel combination of gain-setting resistors R240—R249 and R140—R141. Conduction of Q150A and Q150B is changed by the amount of this current, developing the output voltage across R153 and R253. The output is a push-pull signal, opposite in polarity to the signal applied to the inputs. The value of R240—R249 is selected by VOLTS/DIV switch S240, to determine the gain.

To minimize trace shift as different vertical deflection factors are selected, the outputs at Q150A and Q150B collectors are dc balanced at equal potentials so that the voltage across the gain-setting resistors is zero at all settings of the VOLTS/DIV switch. This dc balancing is achieved by adjusting R227 (Bal) and R127 (ATTENSTEP BAL) with the gates of Q120A and Q120B effectively tied together and the VOLTS/DIV switch set to 1 mV.

Var Bal resistor R159, located in the emitter circuit of constant-current source transistors Q158A and Q158B, is adjusted with a zero input signal to set the voltage across

DIAGRAMS AND CIRCUIT BOARD ILLUSTRATIONS

Symbols

Graphic symbols and class designation letters are based on ANSI Standard Y32.2-1975.

Logic symbology is based on ANSI Y32.14-1973 in terms of positive logic. Logic symbols depict the logic function performed and may differ from the manufacturer's data.

The overline on a signal name indicates that the signal performs its intended function when it is in the low state.

Abbreviations are based on ANSI Y1.1-1972.

Other ANSI standards that are used in the preparation of diagrams by Tektronix, Inc. are:

- Y14.15, 1966 Drafting Practices.
- Y14.2, 1973 Line Conventions and Lettering.
- Y10.5, 1968 Letter Symbols for Quantities Used in Electrical Science and Electrical Engineering.

American National Standard Institute
1430 Broadway
New York, New York 10018

Component Values

Electrical components shown on the diagrams are in the following units unless noted otherwise:

- Capacitors = Values one or greater are in picofarads (pF).
Values less than one are in microfarads (μ F).
- Resistors = Ohms (Ω).

— The information and special symbols below may appear in this manual. —

Assembly Numbers and Grid Coordinates

Each assembly in the instrument is assigned an assembly number (e.g., A20). The assembly number appears on the circuit board outline on the diagram, in the title for the circuit board component location illustration, and in the lookup table for the schematic diagram and corresponding component locator illustration. The Replaceable Electrical Parts list is arranged by assemblies in numerical sequence; the components are listed by component number *(see following illustration for constructing a component number).

The schematic diagram and circuit board component location illustration have grids. A lookup table with the grid coordinates is provided for ease of locating the component. Only the components illustrated on the facing diagram are listed in the lookup table. When more than one schematic diagram is used to illustrate the circuitry on a circuit board, the circuit board illustration may only appear opposite the first diagram on which it was illustrated; the lookup table will list the diagram number of other diagrams that the circuitry of the circuit board appears on.

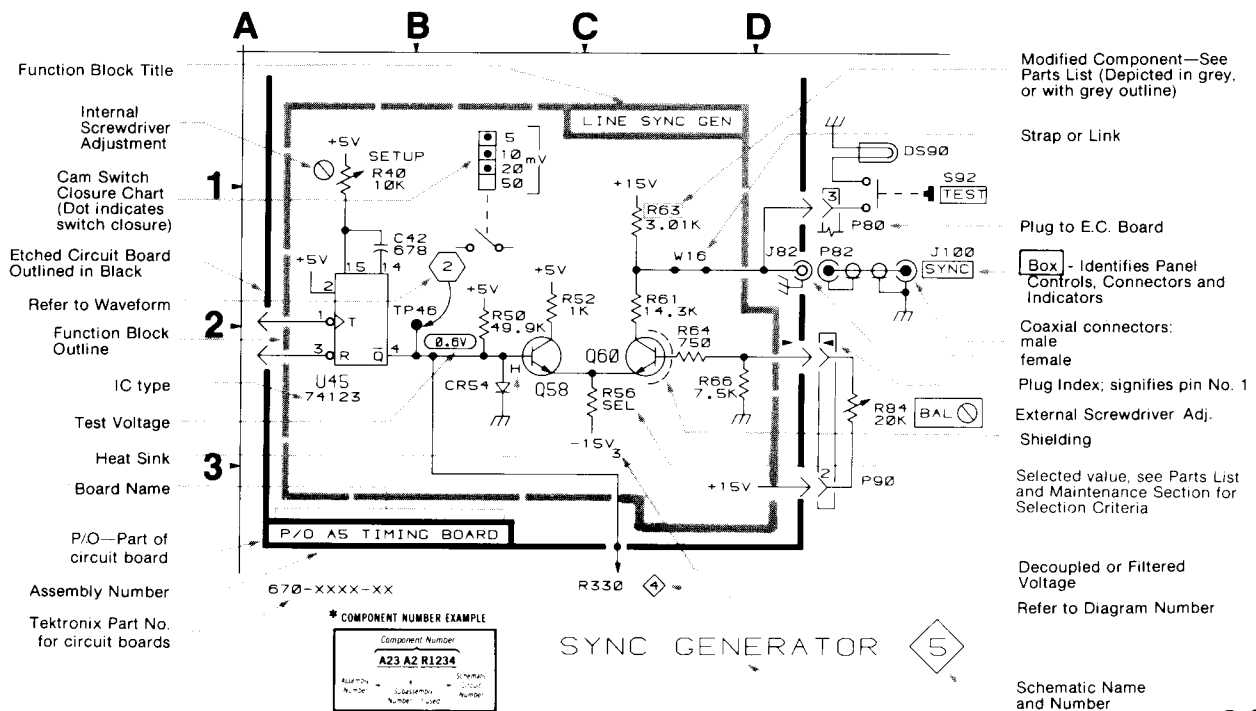

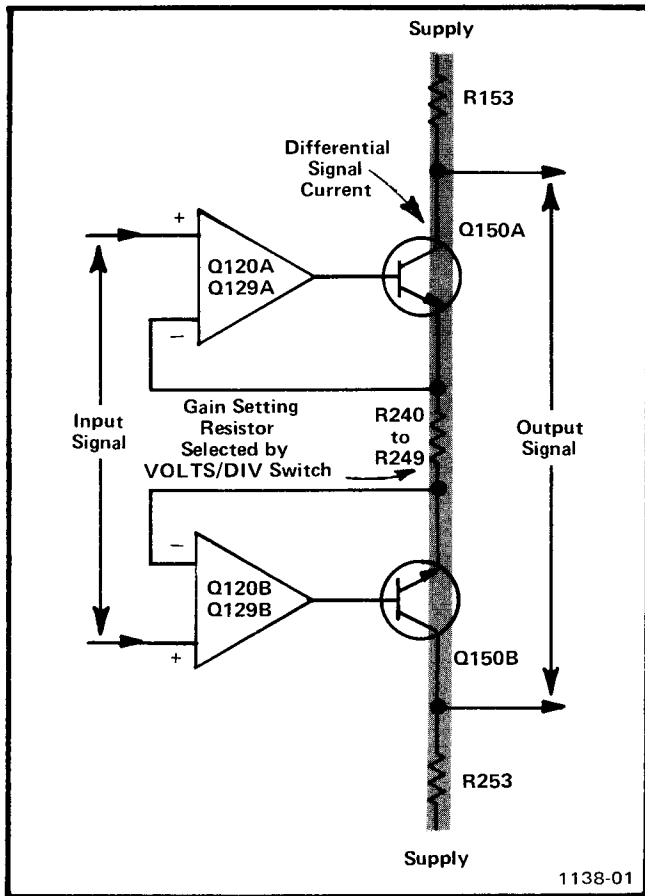

Fig. 3-1. Preampifier detailed block diagram showing signal current paths.

CAL control R169 in the output amplifier stage to 0 V. With both sides of the amplifier so balanced, trace deflection is prevented as the CAL control is rotated throughout its range.

Normally, the frequency response of the preampifier is from dc to at least 1 MHz; however, for low-frequency applications where high input sensitivities are used, the overall frequency response can be limited to about 10 kHz to reduce noise referred to the input. This is achieved by pushing the BANDWIDTH LIMIT 10 kHz switch S259, which connects C259 across the output of the preampifier stage.

Common-Mode Rejection

One of the primary functions of the preampifier is to reject any common-mode component of the input signal and amplify only the difference. Assume that the inputs are tied together and a voltage is applied to the common input. The amplifier differential output is ideally zero, and will actually be zero provided that the characteristics of all corresponding elements on the two sides of the amplifier are matched (e.g., Q120A and Q120B transconductance

and μ , Q129A and Q129B beta, current sources, etc.) In practice, any mismatch causes a differential output.

Floating Power Supply. A floating power supply made up of Q130, Q140, Q146, VR148, and VR149 minimizes inherent common-mode difficulties and therefore improves the common-mode rejection ratio (refer to Fig. 3-2). Transistor Q146 is a constant-current high-impedance source for Q140, and Q130 is the current return for the preampifier stage.

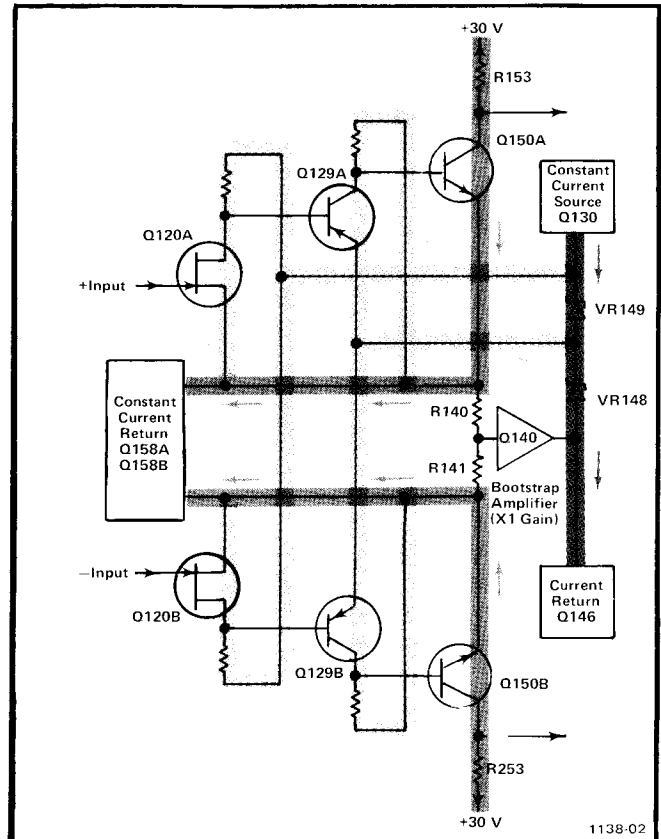

Fig. 3-2. Floating Power Supply detailed block diagram showing standing current paths through the Preampifier.

Bootstrap Amplifier. The input to the bootstrap (X1 gain) amplifier is connected to the junction of R140 and R141. The bootstrap amplifier portion of the supply consists of emitter-follower Q140 and dc level-shifting Zener diodes VR148 and VR149. The collector impedance of Q146 presents minimum loading to the Q140 output and maintains the gain of the amplifier (bootstrap efficiency) very close to one.

Preampifier. The entire power supply and amplifier voltages move an amount equal to the common-mode voltage, maintaining a constant operating characteristic

Theory of Operation—5A21N

of the elements in the preamplifier stage. Since no signal current is developed, the output at the collectors of Q150A and Q150B remains unchanged; that is, the common-mode signal is rejected.

Capacitors C221 (CMRR 2) and C250 (CMRR 1) are adjusted on high-frequency common-mode signals to normalize the effective capacitance of the active devices on one side of the amplifier to the other.

Isolation Stage

The differential signal developed at the collectors of Q150A and Q150B is passed through emitter followers Q160 and Q260 to the output amplifier. Transistors Q160 and Q260 isolate the preamplifier from the loading of the output amplifier and trigger signal amplifier.

Output Amplifier

The output amplifier consists of push-pull amplifier Q163—Q263. With a signal applied, Gain potentiometer R268 provides emitter degeneration; the gain being determined by the total emitter resistance. This allows the overall gain of the 5A21N to be adjusted to match the mainframe requirements. Also, Variable Volts/Div control (CAL) R169 allows gain to be adjustable over a 2.5 to 1 ratio.

Transistors Q170 and Q270 are positioning-current drivers. POSITION Resistor R179 provides an adjustable change in the conduction of the transistors, which provides a current to either add to or subtract from the Q163—Q263 currents to alter the quiescent vertical position of the display.

Trigger Output Amplifier

Differential amplifier Q280—Q286 receives the triggering signal from the emitters of Q160 and Q260 in the isolation stage. The triggering signal is amplified and passed through emitter-follower Q281, where it is made available to an associated time-base unit via output terminal A4. The triggering signal is of the same polarity as that applied to the gate of Q120A, and has an amplitude of about 0.25 V per displayed division.

Attenuator Switching

VOLTS/DIV switch S240 is made up of a series of cam lobes that engage and disengage various contacts at different positions of the switch. Cams 1 through 4 control switching of the input attenuators and cams 5 through 13 control switching of the gain-setting resistor R240—R249 in the preamplifier stage. Those contacts that are engaged at any given position of the switch are shown by black dots on the switch logic diagram.

Knob-Skirt Readout (SN B070000 and up)

Either of two lamp bulbs located behind the knob skirt of the VOLTS/DIV switch illuminates the selected deflection factor to provide a direct readout. Normally, DS185, which is physically located behind the upper left portion of the knob skirt, is lit. Connection of a readout-coded 10X probe to either the + or – input automatically changes the readout by a factor of 10 (i.e., extinguishes DS185 and illuminates DS187) to reflect the correction of probe attenuation, eliminating possible error by the operator of the instrument. The + and – input connectors (J1 and J11) have probe rings, allowing a 10X probe to apply a ground connection to the base of Q183. Transistor Q183 then turns off, thereby turning off Q185 and DS185. Transistor Q185 collector goes positive, allowing Q187 to turn on and switch current to DS187. When the instrument is operated in the CURR PROBE ONLY mode, only DS187 is illuminated to indicate the vertical deflection factor in units of amperes per division.

Knob-Skirt Readout (SN B069999 and below)

Either of two lamp bulbs located behind the knob skirt of the VOLTS/DIV switch illuminates the selected deflection factor to provide a direct readout. Normally, DS182, which is physically located behind the upper left portion of the knob skirt, is lit. Connection of a readout-coded 10X probe to either the + or – input automatically changes the readout by a factor of 10 (i.e., extinguishes DS182 and illuminates DS187) to reflect the correction of probe attenuation, eliminating possible error by the operator of the instrument. J1 and J11, the + and – input connectors, have probe rings, allowing the 10X probe to apply a ground connection at the base of Q182. Q182 turns off, allowing Q187 to turn on, switching current from DS182 to DS187. When the instrument is operated in the CURR PROBE ONLY mode, DS187 is illuminated to indicate the vertical deflection factor in units of amperes per division.

Replaceable Electrical Parts—5A21N

| Ckt No. | Tektronix Part No. | Serial/Model No. Eff | Dscont | Name & Description | Mfr Code | Mfr Part Number |
|---------|--------------------|----------------------|--------|---------------------------------------|----------|-----------------|
| S180 | 260-1209-00 | | | SWITCH,PUSH:4PDT,1A,25VDC | 80009 | 260-1209-00 |
| S240 | 105-0239-00 | | | ACTR ASSY,CAM S:VOLT/DIV | 80009 | 105-0239-00 |
| | ----- | | | (S240, SEE MPL FOR REPLACEMENT PARTS) | | |
| S259 | 260-1208-00 | | | SWITCH,PUSH:DPDT,28VDC,PUSH-PUSH | 80009 | 260-1208-00 |
| VR111 | 152-0168-00 | | | SEMICONV DEVICE:ZENER,0.4W,12V,5% | 04713 | SZG35009K4 |
| VR114 | 152-0168-00 | | | SEMICONV DEVICE:ZENER,0.4W,12V,5% | 04713 | SZG35009K4 |
| VR148 | 152-0280-00 | | | SEMICONV DEVICE:ZENER,0.4W,6.2V,5% | 80009 | 152-0280-00 |
| VR149 | 152-0279-00 | | | SEMICONV DEVICE:ZENER,0.4W,5.1V,5% | 04713 | SZG35010RL |

MAINTENANCE

This section of the manual contains information for performing preventive maintenance, troubleshooting, and corrective maintenance for the 5A21N Differential Amplifier.

PREVENTIVE MAINTENANCE

Preventive maintenance, when performed on a regular basis, can prevent or forestall instrument breakdown and may improve the reliability of the instrument. The severity of the environment to which the instrument is subjected will determine the frequency of maintenance. A convenient time to perform preventive maintenance is preceding electrical adjustment of the instrument.

VISUAL INSPECTION

The 5A12N should be inspected occasionally for such defects as broken connections, improperly seated semiconductors, damaged or improperly installed circuit boards, and heat-damaged parts. The corrective procedure for most visible defects is obvious; however, particular care must be taken if heat-damaged parts are found. Overheating usually indicates other trouble in the instrument; therefore, the cause of overheating must be corrected to prevent recurrence of the damage.

CLEANING

The instrument should be cleaned as often as operating conditions require. Accumulation of dirt in the instrument can cause overheating and component breakdown. Dirt on components acts as an insulating blanket that prevents efficient heat dissipation, and also provides an electrical conduction path which may result in instrument failure. The covers provide some protection against dust in the interior of the instrument.

CAUTION

Avoid the use of chemical cleaning agents that might damage the plastics used in this instrument. Use a nonresidue type of cleaner, preferably isopropyl alcohol or total denatured ethyl alcohol. Before using any other type of cleaner, consult your Tektronix Service Center.

Exterior

Loose dust accumulated on the outside of the instrument can be removed with a soft cloth or small brush. The brush is particularly useful for dislodging dirt on and around the front-panel controls. Dirt that remains can be

removed with a soft cloth dampened in a mild detergent and water solution. Abrasive cleaners should not be used.

Interior

Cleaning the interior of the instrument should be performed in conjunction with the visual inspection. The best way to clean the interior is to blow off the accumulated dust with dry, low-velocity air (approximately 5 lb/in²). Remove any dirt that remains with a soft brush or a cloth dampened with a mild detergent and water solution. A cotton-tipped applicator is useful for cleaning in narrow spaces, or for cleaning more delicate circuit components.

CAUTION

Circuit boards and components must be dry before applying power to the instrument to prevent damage from electrical arcing.

SEMICONDUCTOR CHECKS

Periodic checks of semiconductors are not recommended. The best check of semiconductor performance is actual operation in the instrument. More details on semiconductors are given under Troubleshooting later in this section.

PERIODIC ELECTRICAL ADJUSTMENT

To ensure accurate measurements, check the electrical adjustment of this instrument after each 1000 hours of operation, or every six months if used infrequently. In addition, replacement of components may necessitate adjustment of the affected circuits. Complete adjustment instructions are given in Section 5, Calibration. This procedure can be helpful in localizing certain troubles in the instrument, and in some cases, may correct them.

Replaceable Electrical Parts—5A21N

| Ckt No. | Tektronix Part No. | Serial/Model No. Eff | Dscont | Name & Description | Mfr Code | Mfr Part Number |
|---------|--------------------|----------------------|----------|---|----------|-----------------|
| R182 | 315-0122-00 | XB070000 | | RES., FXD, CMPSN: 1.2K OHM, 5%, 0.25W | 01121 | CB1225 |
| R183 | 315-0272-00 | XB070000 | | RES., FXD, CMPSN: 2.7K OHM, 5%, 0.25W | 01121 | CB2725 |
| R184 | 315-0103-00 | B010100 | B059999 | RES., FXD, CMPSN: 10K OHM, 5%, 0.25W | 01121 | CB1035 |
| R184 | 315-0100-00 | B060000 | B069999X | RES., FXD, CMPSN: 10 OHM, 5%, 0.25W | 01121 | CB1005 |
| R185 | 316-0124-00 | B010100 | B059999X | RES., FXD, CMPSN: 120K OHM, 10%, 0.25W | 01121 | CB1241 |
| R185 | 315-0431-00 | XB070000 | | RES., FXD, CMPSN: 430 OHM, 5%, 0.25W | 01121 | CB4315 |
| R186 | 315-0242-00 | XB070000 | | RES., FXD, CMPSN: 2.4K OHM, 5%, 0.25W | 01121 | CB2425 |
| R187 | 316-0105-00 | B010100 | B059999 | RES., FXD, CMPSN: 1M OHM, 10%, 0.25W | 01121 | CB1051 |
| R187 | 315-0154-00 | B060000 | B069999 | RES., FXD, CMPSN: 150K OHM, 5%, 0.25W | 01121 | CB1545 |
| R187 | 315-0431-00 | B070000 | | RES., FXD, CMPSN: 430 OHM, 5%, 0.25W | 01121 | CB4315 |
| R188 | 315-0112-00 | XB070000 | | RES., FXD, CMPSN: 1.1K OHM, 5%, 0.25W | 01121 | CB1125 |
| R190 | 315-0100-00 | XB070000 | | RES., FXD, CMPSN: 10 OHM, 5%, 0.25W | 01121 | CB1005 |
| R200 | 315-0270-00 | B010100 | B039999X | RES., FXD, CMPSN: 27 OHM, 5%, 0.25W | 01121 | CB2705 |
| R203 | 322-0624-07 | | | RES., FXD, FILM: 990K OHM, 0.1%, 0.25W | 75042 | CEBT0-9903B |
| R206 | 322-0481-07 | | | RES., FXD, FILM: 1M OHM, 0.1%, 0.25W | 91637 | MFF1421C1003B |
| R208 | 321-0289-03 | | | RES., FXD, FILM: 10K OHM, 0.25%, 0.125W | 91637 | MFF1816D10001C |
| R211 | 321-0261-00 | | | RES., FXD, FILM: 5.11K OHM, 1%, 0.125W | 91637 | MFF1816G51100F |
| R220 | 315-0201-00 | | | RES., FXD, CMPSN: 200 OHM, 5%, 0.25W | 01121 | CB2015 |
| R227 | 311-0622-00 | | | RES., VAR, NONWIR: 100 OHM, 10%, 0.50W | 32997 | 3329H-G48-101 |
| R240 | 321-0933-03 | | | RES., FXD, FILM: 6.66K OHM, 0.25%, 0.125W | 91637 | MFF1816D66600C |
| R241 | 321-0932-03 | | | RES., FXD, FILM: 2.5K OHM, 0.25%, 0.125W | 91637 | MFF1816D25000C |
| R242 | 321-0931-03 | | | RES., FXD, FILM: 1.11K OHM, 0.25%, 0.125W | 91637 | MFF1816D11100C |
| R243 | 321-0660-03 | | | RES., FXD, FILM: 417 OHM, 0.25%, 0.125W | 91637 | MFF1816D417ROC |
| R244 | 321-0930-03 | | | RES., FXD, FILM: 204 OHM, 0.25%, 0.125W | 91637 | MFF1816D204ROC |
| R245 | 321-1097-03 | | | RES., FXD, FILM: 101 OHM, 0.25%, 0.125W | 91637 | MFF1816D101ROC |
| R246 | 321-0030-03 | | | RES., FXD, FILM: 20.0 OHM, 0.25%, 0.125W | 91637 | MFF1816D20R00C |
| R249 | 321-0030-03 | | | RES., FXD, FILM: 20.0 OHM, 0.25%, 0.125W | 91637 | MFF1816D20R00C |
| R251 | 321-0222-00 | | | RES., FXD, FILM: 2K OHM, 1%, 0.125W | 91637 | MFF1816G20000F |
| R253 | 321-0231-00 | | | RES., FXD, FILM: 2.49K OHM, 1%, 0.125W | 91637 | MFF1816G24900F |
| R255 | 321-0197-00 | | | RES., FXD, FILM: 1.1K OHM, 1%, 0.125W | 91637 | MFF1816G11000F |
| R256 | 321-0306-00 | | | RES., FXD, FILM: 15K OHM, 1%, 0.125W | 91637 | MFF1816G15001F |
| R257 | 321-0306-00 | | | RES., FXD, FILM: 15K OHM, 1%, 0.125W | 91637 | MFF1816G15001F |
| R258 | 321-0233-00 | | | RES., FXD, FILM: 2.61K OHM, 1%, 0.125W | 91637 | MFF1816G26100F |
| R262 | 315-0153-00 | | | RES., FXD, CMPSN: 15K OHM, 5%, 0.25W | 01121 | CB1535 |
| R267 | 321-0272-00 | | | RES., FXD, FILM: 6.65K OHM, 1%, 0.125W | 91637 | MFF1816G66500F |
| R268 | 311-1120-00 | | | RES., VAR, NONWIR: 100 OHM, 30%, 0.25W | 71450 | 201-YA5531 |
| R274 | 316-0102-00 | B010100 | B073405 | RES., FXD, CMPSN: 1K OHM, 10%, 0.25W | 01121 | CB1021 |
| R274 | 315-0102-00 | B073406 | | RES., FXD, CMPSN: 1K OHM, 5%, 0.25W | 01121 | CB1025 |
| R275 | 321-0184-00 | | | RES., FXD, FILM: 806 OHM, 1%, 0.125W | 91637 | MFF1816G806R0F |
| R278 | 315-0103-00 | | | RES., FXD, CMPSN: 10K OHM, 5%, 0.25W | 01121 | CB1035 |
| R280 | 315-0331-00 | | | RES., FXD, CMPSN: 330 OHM, 5%, 0.25W | 01121 | CB3315 |
| R281 | 316-0102-00 | B010100 | B073405 | RES., FXD, CMPSN: 1K OHM, 10%, 0.25W | 01121 | CB1021 |
| R281 | 315-0102-00 | B073406 | | RES., FXD, CMPSN: 1K OHM, 5%, 0.25W | 01121 | CB1025 |
| R282 | 315-0331-00 | | | RES., FXD, CMPSN: 330 OHM, 5%, 0.25W | 01121 | CB3315 |
| R283 | 321-0251-00 | | | RES., FXD, FILM: 4.02K OHM, 1%, 0.125W | 91637 | MFF1816G40200F |
| R284 | 315-0331-00 | | | RES., FXD, CMPSN: 330 OHM, 5%, 0.25W | 01121 | CB3315 |
| R285 | 315-0331-00 | | | RES., FXD, CMPSN: 330 OHM, 5%, 0.25W | 01121 | CB3315 |
| R286 | 321-0280-00 | | | RES., FXD, FILM: 8.06K OHM, 1%, 0.125W | 91637 | MFF1816G80600F |
| R288 | 316-0392-00 | B010100 | B073405 | RES., FXD, CMPSN: 3.9K OHM, 10%, 0.25W | 01121 | CB3921 |
| R288 | 315-0392-00 | B073406 | | RES., FXD, CMPSN: 3.9K OHM, 5%, 0.25W | 01121 | CB3925 |
| R289 | 316-0181-00 | B010100 | B073405 | RES., FXD, CMPSN: 180 OHM, 10%, 0.25W | 01121 | CB1811 |
| R289 | 315-0181-00 | B073406 | | RES., FXD, CMPSN: 180 OHM, 5%, 0.25W | 01121 | CB1815 |
| S1A) | 260-1210-00 | | | SWITCH, PUSH: 1A, 28VDC | 80009 | 260-1210-00 |
| S1B) | | | | | | |
| S1C) | | | | | | |
| S1D) | | | | | | |
| S1E) | | | | | | |

TROUBLESHOOTING

The following information is provided to facilitate troubleshooting of the 5A21N. Information contained in other sections of this manual should be used in conjunction with the following data to aid in locating a defective component. An understanding of the circuit operation is helpful in locating troubles. See Section 3 (Theory of Operation) for this information.

TROUBLESHOOTING AIDS

Diagrams

Complete schematic diagrams are located on the foldout pages in Section 8 (Diagrams and Circuit Board Illustrations). The component number and electrical value of each component in this instrument is shown on these diagrams. (See the first page of the Diagrams and Circuit Board Illustrations section for definitions of the reference designators and symbols used to identify components in this instrument.) Important voltages and numbered waveform test points are also shown on the diagrams. Corresponding numbered waveforms are located adjacent to each diagram. The portions of circuits mounted on the circuit board are enclosed with heavy solid black lines. The diagram is arranged in a grid locator with an index to facilitate rapid location of circuit numbers.

Circuit Board Illustrations

A component location illustration appears on the back of the foldout page facing the schematic diagram. This illustration helps to identify the physical location of the components and waveform test points that appear on the schematic diagram. The circuit board illustration is arranged in a grid locator with an index to facilitate rapid location of components contained on the circuit board.

Component Color Coding

The instrument contains brown composition resistors and some metal-film resistors. The resistance values of composition resistors and metal-film resistors are color coded on the components using the EIA color code (some metal-film resistors may have the value printed on the body). The color code is read starting with the stripe nearest the end of the resistor. Composition resistors have four stripes, which consist of two significant figures, a multiplier, and a tolerance value (see Fig. 4-1). Metal film resistors have five stripes consisting of three significant figures, a multiplier, and a tolerance value.

The values of common disc capacitors and small electrolytics are marked on the side instrument are color coded using a modified EIA code. (see Fig. 4-1).

The cathode end of glass-encased diodes is indicated by a stripe, a series of stripes, or a dot. The cathode and anode ends of metal-encased diodes can be identified by the diode symbol marked on the body.

Semiconductor Lead Configurations

Figure 4-2 shows the lead configurations of the semiconductors used in the 5A21N.

Troubleshooting Equipment

The following equipment, in addition to that listed in the Calibration section, is useful for troubleshooting the 5A21N.

Semiconductor Tester

Description: Dynamic-type tester.

Purpose: To test the semiconductors used in this instrument.

Recommended Type: TEKTRONIX 576 Curve Tracer or TEKTRONIX 577/177 Curve Tracer system, 5CT1N Curve Tracer unit and a 5000-series oscilloscope system, or a 7CT1N Curve Tracer unit and a 7000-series oscilloscope system.

Multimeter

Description: Voltmeter, 10 M Ω input impedance and 0 to 250 V range; accuracy, within 0.1%. Ohmmeter, 0 to 20 M Ω ; accuracy, within 3%. Test probes must be insulated to prevent accidental shorting.

Purpose: To check voltages and for general troubleshooting in this instrument.

Recommended Type: TEKTRONIX DM 501A Option 02 Digital Multimeter (requires a TM 500-series power module).

Test Oscilloscope

Description: Frequency response, dc to 2 MHz minimum; deflection factor, 1 mV to 5 volts/division. A 10X, 10 M Ω voltage probe should be used to reduce circuit loading.

Purpose: To check operating waveforms and for general troubleshooting.

Recommended Type: TEKTRONIX 5110, 5A13N, 5B10N oscilloscope system or equivalent with a TEKTRONIX P6060, P6062B or P6055 10X probe.

Replaceable Electrical Parts—5A21N

| Ckt No. | Tektronix Part No. | Serial/Model No. Eff | Dscont | Name & Description | Mfr Code | Mfr Part Number |
|---------|--------------------|----------------------|----------|---|----------|-----------------|
| R21 | 316-0102-00 | B010100 | B073405 | RES., FXD, CMPSN: 1K OHM, 10%, 0.25W | 01121 | CB1021 |
| R21 | 315-0102-00 | B073406 | | RES., FXD, CMPSN: 1K OHM, 5%, 0.25W | 01121 | CB1025 |
| R22 | 316-0100-00 | B010100 | B073405 | RES., FXD, CMPSN: 10 OHM, 10%, 0.25W | 01121 | CB1001 |
| R22 | 315-0100-00 | B073406 | | RES., FXD, CMPSN: 10 OHM, 5%, 0.25W | 01121 | CB1005 |
| R23 | 321-0292-00 | | | RES., FXD, FILM: 10.7K OHM, 1%, 0.125W | 91637 | MFF1816G10701F |
| R24 | 321-0210-00 | B010100 | B039999 | RES., FXD, FILM: 1.5K OHM, 1%, 0.125W | 91637 | MFF1816G15000F |
| R24 | 321-0222-00 | B040000 | | RES., FXD, FILM: 2K OHM, 1%, 0.125W | 91637 | MFF1816G20000F |
| R25 | 315-0101-00 | | | RES., FXD, CMPSN: 100 OHM, 5%, 0.25W | 01121 | CB1015 |
| R27 | 315-0203-00 | | | RES., FXD, CMPSN: 20K OHM, 5%, 0.25W | 01121 | CB2035 |
| R32 | 321-0248-00 | B010100 | B039999 | RES., FXD, FILM: 3.74K OHM, 1%, 0.125W | 91637 | MFF1816G37400F |
| R32 | 321-0250-00 | B040000 | | RES., FXD, FILM: 3.92K OHM, 1%, 0.125W | 91637 | MFF1816G39200F |
| R33 | 321-0222-00 | | | RES., FXD, FILM: 2K OHM, 1%, 0.125W | 91637 | MFF1816G20000F |
| R35 | 304-0122-00 | | | RES., FXD, CMPSN: 1.2K OHM, 10%, 1W | 01121 | GB1221 |
| R36 | 321-0068-00 | | | RES., FXD, FILM: 49.9 OHM, 1%, 0.125W | 91637 | MFF1816G49R90F |
| R37 | 321-0010-00 | | | RES., FXD, FILM: 12.4 OHM, 1%, 0.125W | 91637 | MFF1816G12R40F |
| R100 | 315-0270-00 | B010100 | B039999X | RES., FXD, CMPSN: 27 OHM, 5%, 0.25W | 01121 | CB2705 |
| R103 | 322-0624-07 | | | RES., FXD, FILM: 990K OHM, 0.1%, 0.25W | 75042 | CEBTO-9903B |
| R106 | 322-0481-07 | | | RES., FXD, FILM: 1M OHM, 0.1%, 0.25W | 91637 | MFF1421C1003B |
| R108 | 321-0289-03 | | | RES., FXD, FILM: 10K OHM, 0.25%, 0.125W | 91637 | MFF1816D10001C |
| R109 | 311-0605-00 | | | RES., VAR, NONWIR: TRMR, 200 OHM, 0.5W | 73138 | 82-23-2 |
| R111 | 315-0153-00 | | | RES., FXD, CMPSN: 15K OHM, 5%, 0.25W | 01121 | CB1535 |
| R114 | 315-0242-00 | | | RES., FXD, CMPSN: 2.4K OHM, 5%, 0.25W | 01121 | CB2425 |
| R120 | 315-0201-00 | | | RES., FXD, CMPSN: 200 OHM, 5%, 0.25W | 01121 | CB2015 |
| R121 | 321-0261-00 | | | RES., FXD, FILM: 5.11K OHM, 1%, 0.125W | 91637 | MFF1816G51100F |
| R125 | 321-0078-00 | | | RES., FXD, FILM: 63.4 OHM, 1%, 0.125W | 91637 | MFF1816G63R40F |
| R126 | 321-0126-00 | | | RES., FXD, FILM: 200 OHM, 1%, 0.125W | 91637 | MFF1816G200R0F |
| R127 | 311-1116-00 | | | RES., VAR, NONWIR: 100 OHM, 20%, 0.50W | 01121 | WA1G032S101MA |
| R131 | 315-0270-00 | | | RES., FXD, CMPSN: 27 OHM, 5%, 0.25W | 01121 | CB2705 |
| R135 | 315-0331-00 | | | RES., FXD, CMPSN: 330 OHM, 5%, 0.25W | 01121 | CB3315 |
| R137 | 315-0362-00 | | | RES., FXD, CMPSN: 3.6K OHM, 5%, 0.25W | 01121 | CB3625 |
| R140 | 321-0816-03 | | | RES., FXD, FILM: 5K OHM, 0.25%, 0.125W | 91637 | MFF1816D50000C |
| R141 | 321-0816-03 | | | RES., FXD, FILM: 5K OHM, 0.25%, 0.125W | 91637 | MFF1816D50000C |
| R144 | 315-0153-00 | | | RES., FXD, CMPSN: 15K OHM, 5%, 0.25W | 01121 | CB1535 |
| R145 | 315-0153-00 | | | RES., FXD, CMPSN: 15K OHM, 5%, 0.25W | 01121 | CB1535 |
| R146 | 315-0682-00 | | | RES., FXD, CMPSN: 6.8K OHM, 5%, 0.25W | 01121 | CB6825 |
| R151 | 321-0222-00 | | | RES., FXD, FILM: 2K OHM, 1%, 0.125W | 91637 | MFF1816G20000F |
| R152 | 321-0216-00 | | | RES., FXD, FILM: 1.74K OHM, 1%, 0.125W | 91637 | MFF1816G17400F |
| R153 | 321-0231-00 | | | RES., FXD, FILM: 2.49K OHM, 1%, 0.125W | 91637 | MFF1816G24900F |
| R155 | 321-0197-00 | | | RES., FXD, FILM: 1.1K OHM, 1%, 0.125W | 91637 | MFF1816G11000F |
| R158 | 321-0233-00 | | | RES., FXD, FILM: 2.61K OHM, 1%, 0.125W | 91637 | MFF1816G26100F |
| R159 | 311-1120-00 | | | RES., VAR, NONWIR: 100 OHM, 30%, 0.25W | 71450 | 201-YA5531 |
| R162 | 315-0153-00 | | | RES., FXD, CMPSN: 15K OHM, 5%, 0.25W | 01121 | CB1535 |
| R167 | 321-0272-00 | | | RES., FXD, FILM: 6.65K OHM, 1%, 0.125W | 91637 | MFF1816G66500F |
| R168 | 321-0182-00 | B010100 | B039999 | RES., FXD, FILM: 768 OHM, 1%, 0.125W | 91637 | MFF1816G768R0F |
| R168 | 321-0181-00 | B040000 | | RES., FXD, FILM: 750 OHM, 1%, 0.125W | 91637 | MFF1816G750R0F |
| R169 | 311-1121-00 | B010100 | B069999 | RES., VAR, NONWIR: 2K OHM, 20%, 0.5W | 34263 | A45-CPS |
| R169 | 311-1990-00 | B070000 | | RES., VAR, NONWIR: PNL, 2.5K OHM, 20%, 0.5W | 01121 | 17M654 |
| R170 | 315-0912-00 | | | RES., FXD, CMPSN: 9.1K OHM, 5%, 0.25W | 01121 | CB9125 |
| R171 | 315-0513-00 | | | RES., FXD, CMPSN: 51K OHM, 5%, 0.25W | 01121 | CB5135 |
| R174 | 316-0102-00 | B010100 | B073405 | RES., FXD, CMPSN: 1K OHM, 10%, 0.25W | 01121 | CB1021 |
| R174 | 315-0102-00 | B073406 | | RES., FXD, CMPSN: 1K OHM, 5%, 0.25W | 01121 | CB1025 |
| R175 | 321-0184-00 | | | RES., FXD, FILM: 806 OHM, 1%, 0.125W | 91637 | MFF1816G806R0F |
| R178 | 315-0103-00 | | | RES., FXD, CMPSN: 10K OHM, 5%, 0.25W | 01121 | CB1035 |
| R179 | 311-0310-01 | B010100 | B039999 | RES., VAR, NONWIR: 5K OHM, 20%, 0.50W | 01121 | W-7350B |
| R179 | 311-1368-00 | B040000 | | RES., VAR, NONWIR: 5K OHM, 20%, 1W | 01121 | 73A1G04GL502M |
| R181 | 316-0154-00 | B010100 | B069999 | RES., FXD, CMPSN: 150K OHM, 10%, 0.25W | 01121 | CB1541 |
| R181 | 315-0274-00 | B070000 | | RES., FXD, CMPSN: 270K OHM, 5%, 0.25W | 01121 | CB2745 |
| R182 | 316-0105-00 | B010100 | B059999X | RES., FXD, CMPSN: 1M OHM, 10%, 0.25W | 01121 | CB1051 |

COLOR CODE

① ② AND ③ - 1st, 2nd, AND 3rd SIGNIFICANT FIGS.

Ⓣ AND/OR ⓉⓈ COLOR CODE MAY NOT BE PRESENT ON SOME CAPACITORS;

Ⓜ - MULTIPLIER; Ⓣ - TOLERANCE;

Ⓟ - POSITIVE (+) POLARITY AND VOLTAGE RATING.

ⓉⓈ - TEMPERATURE COEFFICIENT.

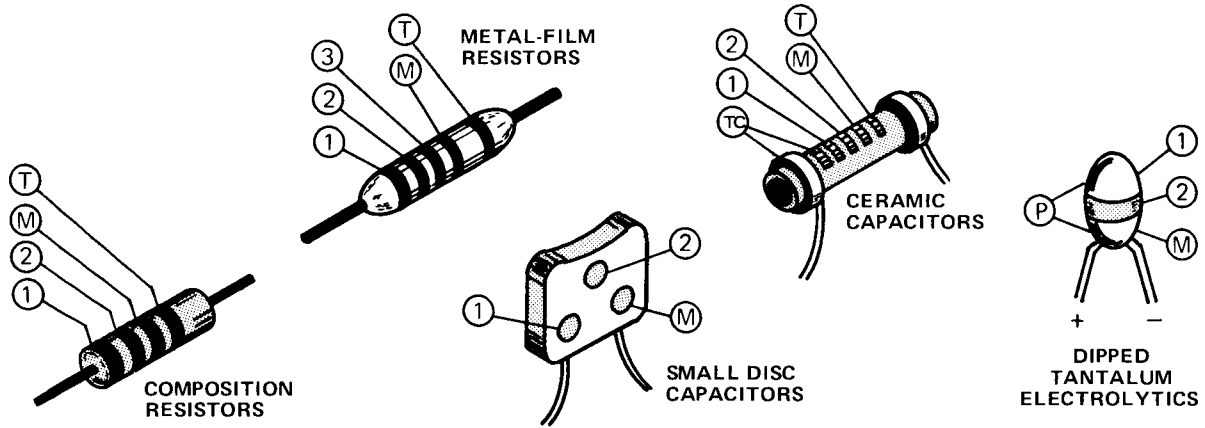

| COLOR | SIGNIFICANT FIGURES | RESISTORS | | CAPACITORS | | | DIPPED TANTALUM VOLTAGE RATING |
|--------|---------------------|--------------------------|-----------|-------------------------------|--------------|------------|--------------------------------|
| | | MULTIPLIER (OHMS) | TOLERANCE | MULTIPLIER (pF) | TOLERANCE | | |
| | | | | | OVER 10pF | UNDER 10pF | |
| BLACK | 0 | 1 | --- | 1 | ±20% | ± 2pF | 4VDC |
| BROWN | 1 | 10 | ±1% | 10 | ±1% | ±0.1pF | 6VDC |
| RED | 2 | 10 ² or 100 | ±2% | 10 ² or 100 | ±2% | --- | 10VDC |
| ORANGE | 3 | 10 ³ or 1 K | ±3% | 10 ³ or 1000 | ±3% | --- | 15VDC |
| YELLOW | 4 | 10 ⁴ or 10K | ±4% | 10 ⁴ or 10,000 | +100% -0% | --- | 20VDC |
| GREEN | 5 | 10 ⁵ or 100 K | ±1/2% | 10 ⁵ or 100,000 | ±5% | ±0.5pF | 25VDC |
| BLUE | 6 | 10 ⁶ or 1 M | ±1/4% | 10 ⁶ or 1,000,000 | --- | --- | 35VDC |
| VIOLET | 7 | --- | ±1/10% | 10 ⁷ or 10,000,000 | --- | --- | 50VDC |
| GRAY | 8 | --- | --- | 10 ⁻² or 0.01 | +80% -20% | ±0.25pF | --- |
| WHITE | 9 | --- | --- | 10 ⁻¹ or 0.1 | ±10% | ±1pF | 3VDC |
| GOLD | --- | 10 ⁻¹ or 0.1 | ±5% | --- | --- | --- | --- |
| SILVER | --- | 10 ⁻² or 0.01 | ±10% | --- | --- | --- | --- |
| NONE | --- | --- | ±20% | --- | ±10% | ±1pF | --- |

(1862-74) 1866-57

Fig. 4-1. Color code for resistors and capacitors.

Replaceable Electrical Parts—5A21N

| Ckt No. | Tektronix Part No. | Serial/Model No. Eff | Dscont | Name & Description | Mfr Code | Mfr Part Number |
|----------|--------------------|----------------------|----------|---|----------|-----------------|
| CR112 | 152-0324-00 | | | SEMICONV DEVICE:SILICON,35V,100MA | 03508 | DE103 |
| CR113 | 152-0324-00 | | | SEMICONV DEVICE:SILICON,35V,100MA | 03508 | DE103 |
| CR114 | 152-0324-00 | | | SEMICONV DEVICE:SILICON,35V,100MA | 03508 | DE103 |
| CR163 | 152-0141-02 | | | SEMICONV DEVICE:SILICON,30V,150MA | 01295 | 1N4152R |
| CR263 | 152-0141-02 | | | SEMICONV DEVICE:SILICON,30V,150MA | 01295 | 1N4152R |
| DS1 | 150-0049-00 | XB084881 | | LAMP, INCAND: 5V, 0.06A, #6835, AXIAL LEADS | 92966 | 8635 |
| DS2 | 150-0049-00 | XB084881 | | LAMP, INCAND: 5V, 0.06A, #6835, AXIAL LEADS | 92966 | 6835 |
| DS182 | 150-0111-00 | B010100 | B059999 | LAMP, GLOW: NEON, 1.2MA | 53944 | A1B-3 |
| DS182 | 150-0130-00 | B060000 | B069999X | LAMP, INCAND: 5V, 60MA | 92966 | 34254-TINNED |
| DS185 | 150-0130-00 | XB070000 | | LAMP, INCAND: 5V, 60MA | 92966 | 34254-TINNED |
| DS187 | 150-0111-00 | B010100 | B059999 | LAMP, GLOW: NEON, 1.2MA | 53944 | A1B-3 |
| DS187 | 150-0130-00 | B060000 | | LAMP, INCAND: 5V, 60MA | 92966 | 34254-TINNED |
| F20 | 159-0024-00 | | | FUSE, CARTRIDGE: 3AG, 0.062A, 250V, 0.3 SEC | 71400 | MGM 1/16 |
| F206 | 159-0024-00 | | | FUSE, CARTRIDGE: 3AG, 0.062A, 250V, 0.3 SEC | 71400 | MGM 1/16 |
| J1 | 131-0679-00 | B010100 | B041688 | CONNECTOR, RCPT, : BNC, MALE, 3 CONTACT | 24931 | 28JR168-1 |
| J1 | 131-0679-02 | B041689 | | CONNECTOR, RCPT, : BNC, MALE, 3 CONTACT | 24931 | 28JR270-1 |
| J11 | 131-0679-00 | B010100 | B041688 | CONNECTOR, RCPT, : BNC, MALE, 3 CONTACT | 24931 | 28JR168-1 |
| J11 | 131-0679-02 | B041689 | | CONNECTOR, RCPT, : BNC, MALE, 3 CONTACT | 24931 | 28JR270-1 |
| J21 | 131-0955-00 | | | CONN, RCPT, ELEC: BNC, FEMALE | 13511 | 31-279 |
| L174 | 108-0200-00 | | | COIL, RF: 40UH | 80009 | 108-0200-00 |
| L189 | 108-0245-00 | XB084949 | | COIL, RF: 3.9UH | 76493 | B6310-1 |
| L274 | 108-0200-00 | | | COIL, RF: 40UH | 80009 | 108-0200-00 |
| LR100 | 108-0565-00 | XB040000 | | COIL, RF: FIXED, 5UH | 80009 | 108-0565-00 |
| LR120 | 108-0565-00 | XB050000 | | COIL, RF: FIXED, 5UH | 80009 | 108-0565-00 |
| LR200 | 108-0565-00 | XB040000 | | COIL, RF: FIXED, 5UH | 80009 | 108-0565-00 |
| LR220 | 108-0565-00 | XB050000 | | COIL, RF: FIXED, 5UH | 80009 | 108-0565-00 |
| Q20A, B | 151-0308-00 | | | TRANSISTOR: SILICON, NPN | 80009 | 151-0308-00 |
| Q30 | 151-0219-00 | B010100 | B039999 | TRANSISTOR: SILICON, PNP | 07263 | S022650 |
| Q30 | 151-0164-00 | B040000 | | TRANSISTOR: SILICON, PNP | 01295 | SRB3334 |
| Q120A, B | 151-1049-00 | | | TRANSISTOR: SILICON, JFE, N-CHANNEL, DUAL | 80009 | 151-1049-00 |
| Q129A, B | 151-0261-00 | B010100 | B073565 | TRANSISTOR: SILICON, PNP, DUAL | 04713 | SD441 |
| Q129A, B | 151-0261-01 | B073566 | | TRANSISTOR: SILICON, PNP, DUAL, LOW NOISE | 04713 | SD441-1 |
| Q130 | 151-0220-00 | | | TRANSISTOR: SILICON, PNP | 07263 | S036228 |
| Q140 | 151-0273-00 | | | TRANSISTOR: SILICON, NPN | 80009 | 151-0273-00 |
| Q146 | 151-0341-00 | | | TRANSISTOR: SILICON, NPN | 07263 | S040065 |
| Q150A, B | 151-0232-00 | | | TRANSISTOR: SILICON, NPN, DUAL | 07263 | SP12141 |
| Q158A, B | 151-0232-00 | | | TRANSISTOR: SILICON, NPN, DUAL | 07263 | SP12141 |
| Q160 | 151-0341-00 | | | TRANSISTOR: SILICON, NPN | 07263 | S040065 |
| Q163 | 151-0219-00 | | | TRANSISTOR: SILICON, PNP | 07263 | S022650 |
| Q170 | 151-0341-00 | | | TRANSISTOR: SILICON, NPN | 07263 | S040065 |
| Q182 | 151-0347-00 | B010100 | B059999 | TRANSISTOR: SILICON, NPN | 56289 | 2N5551 |
| Q182 | 151-0281-00 | B060000 | B069999X | TRANSISTOR: SILICON, NPN | 03508 | X16P4039 |
| Q183 | 151-0192-00 | XB070000 | | TRANSISTOR: SILICON, NPN, SEL FROM MPS6521 | 04713 | SPS8801 |
| Q185 | 151-0190-00 | XB070000 | | TRANSISTOR: SILICON, NPN | 07263 | S032677 |
| Q187 | 151-0347-00 | B010100 | B059999 | TRANSISTOR: SILICON, NPN | 56289 | 2N5551 |
| Q187 | 151-0281-00 | B060000 | B069999 | TRANSISTOR: SILICON, NPN | 03508 | X16P4039 |
| Q187 | 151-0190-00 | B070000 | | TRANSISTOR: SILICON, NPN | 07263 | S032677 |
| Q260 | 151-0341-00 | | | TRANSISTOR: SILICON, NPN | 07263 | S040065 |
| Q263 | 151-0219-00 | | | TRANSISTOR: SILICON, PNP | 07263 | S022650 |
| Q270 | 151-0341-00 | | | TRANSISTOR: SILICON, NPN | 07263 | S040065 |
| Q280 | 151-0219-00 | | | TRANSISTOR: SILICON, PNP | 07263 | S022650 |
| Q281 | 151-0341-00 | | | TRANSISTOR: SILICON, NPN | 07263 | S040065 |
| Q286 | 151-0219-00 | | | TRANSISTOR: SILICON, PNP | 07263 | S022650 |
| R4 | 316-0105-00 | B010100 | B073405 | RES. , FXD, CMPSN: 1M OHM, 10%, 0.25W | 01121 | CB1051 |
| R4 | 315-0105-00 | B073406 | | RES. , FXD, CMPSN: 1M OHM, 5%, 0.25W | 01121 | CB1055 |
| R14 | 316-0105-00 | B010100 | B073405 | RES. , FXD, CMPSN: 1M OHM, 10%, 0.25W | 01121 | CB1051 |
| R14 | 315-0105-00 | B073406 | | RES. , FXD, CMPSN: 1M OHM, 5%, 0.25W | 01121 | CB1055 |

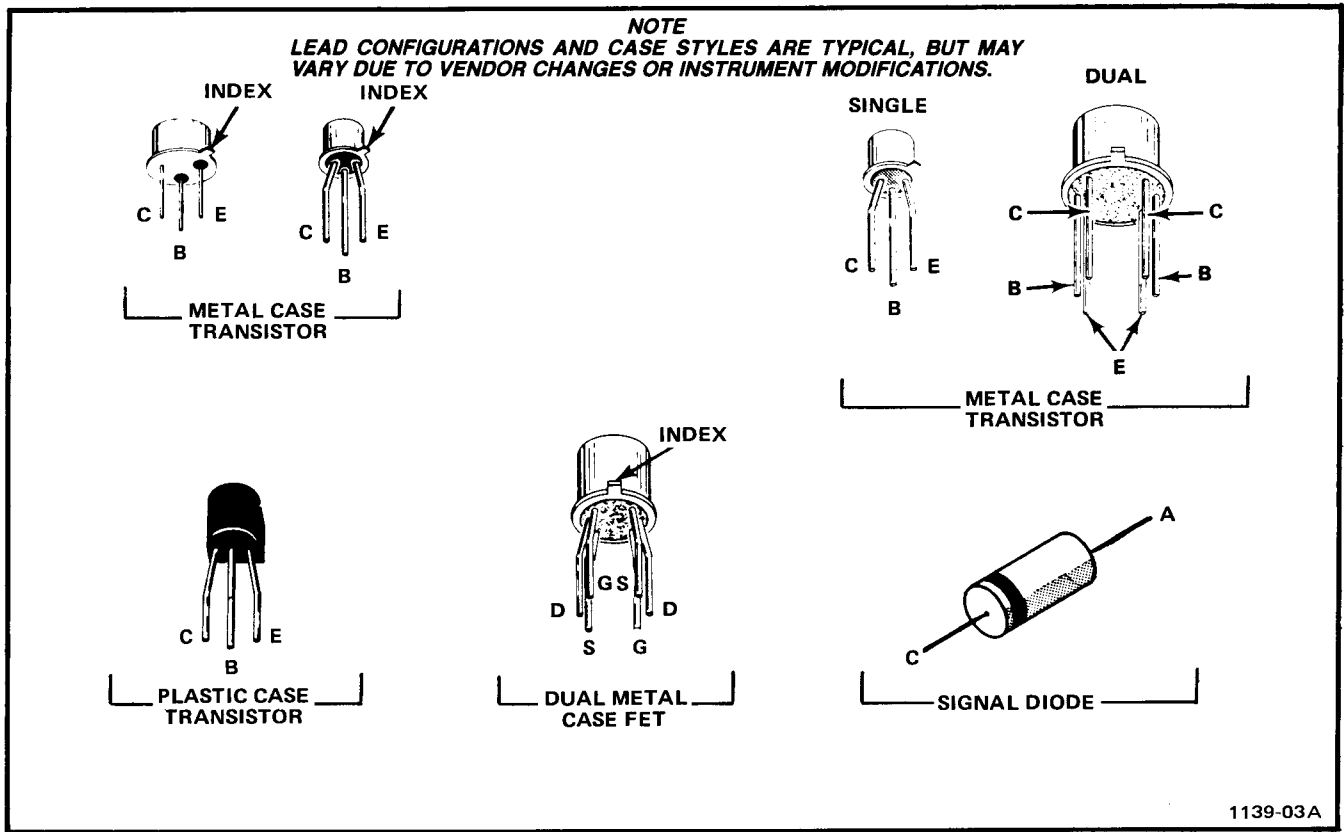

Fig. 4-2. Semiconductor lead configurations.

TROUBLESHOOTING TECHNIQUES

This troubleshooting procedure is arranged in an order that checks the simple trouble possibilities before proceeding with extensive troubleshooting. The first few steps check proper connection, operation, and adjustment. If the trouble is located by these checks, the remaining steps aid in locating the defective component. When the defective component is located, replace it using the replacement procedure given under Component Replacement in this section.

1. Check Control Settings

Incorrect control settings can indicate a trouble that does not exist. If there is any question about the correct function or operation of any control on the 5A21N, refer to Section 2 (Operating Instructions).

2. Check Associated Equipment

Before proceeding with troubleshooting, check that the equipment used with this instrument is operating correctly. Also, check that the input signals are properly connected and that the interconnecting cables are not defective. Check the line-voltage source.

WARNING

Although the 5A21N is not to be connected to a patient, interconnecting the instrument to other equipment can result in the application of excessive current to a patient. It is extremely important that the interconnection is made in accordance with NFPA 76B-T, Tentative Standard for the Safe Use of Electricity in Patient Care Areas of Health Care Facilities, section 3038, "Signal Transmission Between Appliances".

3. Visual Check

Visually check that portion of the instrument in which the trouble is located. Many troubles can be found by visible indications, such as unsoldered connections, broken wires, damaged circuit boards, and damaged components.

4. Check Instrument Adjustment

Check the electrical adjustment of this instrument, or of the affected circuit if the trouble appears in one circuit. The apparent trouble may only be a result of misadjust-

Replaceable Electrical Parts—5A21N

| Ckt No. | Tektronix Part No. | Serial/Model No. Eff | Dscont | Name & Description | Mfr Code | Mfr Part Number |
|---------|--------------------|----------------------|----------|--|----------|------------------|
| A1 | 670-1344-00 | B010100 | B039999 | CKT BOARD ASSY:MAIN | 80009 | 670-1344-00 |
| A1 | 670-1344-01 | B040000 | B059999 | CKT BOARD ASSY:MAIN | 80009 | 670-1344-01 |
| A1 | 670-1344-02 | B060000 | B069999 | CKT BOARD ASSY:MAIN | 80009 | 670-1344-02 |
| A1 | 670-1344-03 | B070000 | | CKT BOARD ASSY:MAIN | 80009 | 670-1344-03 |
| C1 | 281-0081-00 | | | CAP.,VAR,AIR DI:1.8-13PF,375VDC | 74970 | 189-0506-075 |
| C2 | 281-0078-00 | | | CAP.,VAR,AIR DI:1.4-7.3PF,750V | 74970 | 189-0503-075 |
| C3 | 281-0081-00 | | | CAP.,VAR,AIR DI:1.8-13PF,375VDC | 74970 | 189-0506-075 |
| C4 | 295-0142-00 | | | CAP SET,MATCHED:(2) 0.1UF,MATCHED +/-0.1% (C4 AND C14 ARE A MATCHED PAIR) | 80009 | 295-0142-00 |
| C11 | 281-0081-00 | | | CAP.,VAR,AIR DI:1.8-13PF,375VDC | 74970 | 189-0506-075 |
| C12 | 281-0078-00 | | | CAP.,VAR,AIR DI:1.4-7.3PF,750V | 74970 | 189-0503-075 |
| C13 | 281-0081-00 | | | CAP.,VAR,AIR DI:1.8-13PF,375VDC | 74970 | 189-0506-075 |
| C14 | 295-0142-00 | | | CAP SET,MATCHED:(2) 0.1UF,MATCHED +/-0.1% (C14 AND C4 ARE A MATCHED PAIR) | 80009 | 295-0142-00 |
| C22 | 290-0267-00 | | | CAP.,FXD,ELCTLT:1UF,20%,35V | 56289 | 162D105X0035CD2 |
| C25 | 283-0080-00 | | | CAP.,FXD,CER DI:0.022UF,+80-20%,25V | 91418 | MX22322504R0 |
| C27 | 281-0546-00 | | | CAP.,FXD,CER DI:330PF,10%,500V | 04222 | 7001-1380 |
| C32 | 290-0297-00 | | | CAP.,FXD,ELCTLT:39UF,10%,10V | 56289 | 150D396X9010B2 |
| C33 | 281-0579-00 | | | CAP.,FXD,CER DI:21PF,5%,500V | 59660 | 301-050C0G0210J |
| C36 | 290-0264-00 | | | CAP.,FXD,ELCTLT:0.22UF,10%,35V | 56289 | 162D224X9035BC2 |
| C37 | 290-0264-00 | | | CAP.,FXD,ELCTLT:0.22UF,10%,35V | 56289 | 162D224X9035BC2 |
| C38 | 283-0003-00 | XB040000 | | CAP.,FXD,CER DI:0.01UF,+80-20%,150V | 91418 | SP103Z151-4R9 |
| C101 | 281-0658-00 | B010100 | B069999 | CAP.,FXD,CER DI:6.2PF,+/-0.25PF,500V | 59660 | 301-000C0H0629C |
| C101 | 281-0604-00 | B070000 | | CAP.,FXD,CER DI:2.2PF,+/-0.25PF,500V | 04222 | 7001-1336 |
| C104 | 281-0628-00 | B010100 | B029999 | CAP.,FXD,CER DI:15PF,5%,500V | 59660 | 301-000C0G0150J |
| C104 | 281-0657-00 | B030000 | | CAP.,FXD,CER DI:13PF,2%,500V | 59660 | 374-018-C0G0130G |
| C108 | 283-0626-00 | | | CAP.,FXD,MICA D:1800PF,5%,500V | 00853 | D195F182J0 |
| C111 | 290-0267-00 | | | CAP.,FXD,ELCTLT:1UF,20%,35V | 56289 | 162D105X0035CD2 |
| C121 | 281-0604-00 | | | CAP.,FXD,CER DI:2.2PF,+/-0.25PF,500V | 04222 | 7001-1336 |
| C122 | 281-0604-00 | | | CAP.,FXD,CER DI:2.2PF,+/-0.25PF,500V | 04222 | 7001-1336 |
| C129 | 281-0709-00 | | | CAP.,FXD,CER DI:7PF,+/-0.1PF,500V | 59660 | 374005C0H0709B |
| C131 | 281-0504-00 | | | CAP.,FXD,CER DI:10PF,+/-1PF,500V | 59660 | 301-055C0G0100F |
| C135 | 290-0267-00 | | | CAP.,FXD,ELCTLT:1UF,20%,35V | 56289 | 162D105X0035CD2 |
| C140 | 281-0534-00 | B010100 | B039999 | CAP.,FXD,CER DI:3.3PF,+/-0.25PF,500V | 04222 | 7001-1316 |
| C140 | 281-0504-00 | B040000 | | CAP.,FXD,CER DI:10PF,+/-1PF,500V | 59660 | 301-055C0G0100F |
| C148 | 290-0297-00 | | | CAP.,FXD,ELCTLT:39UF,10%,10V | 56289 | 150D396X9010B2 |
| C149 | 290-0297-00 | | | CAP.,FXD,ELCTLT:39UF,10%,10V | 56289 | 150D396X9010B2 |
| C150 | 281-0618-00 | | | CAP.,FXD,CER DI:4.7PF,+/-0.5PF,200V | 59660 | 374-018C0H0-479D |
| C158 | 281-0504-00 | | | CAP.,FXD,CER DI:10PF,+/-1PF,500V | 59660 | 301-055C0G0100F |
| C163 | 281-0540-00 | | | CAP.,FXD,CER DI:51PF,5%,500V | 59660 | 301-000U2J0510J |
| C170 | 283-0000-00 | | | CAP.,FXD,CER DI:0.001UF,+100-0%,500V | 59660 | 831-519-25U-102P |
| C181 | 283-0002-00 | | | CAP.,FXD,CER DI:0.01UF,+80-20%,500V | 91418 | SM103Z5014R9 |
| C184 | 283-0002-00 | B010100 | B059999X | CAP.,FXD,CER DI:0.01UF,+80-20%,500V | 91418 | SM103Z5014R9 |
| C189 | 290-0746-00 | XB084949 | | CAP.,FXD,ELCTLT:47UF,+50-10%,16V | 55680 | 16U-47V-T |
| C204 | 281-0628-00 | B010100 | B029999 | CAP.,FXD,CER DI:15PF,5%,500V | 59660 | 301-000C0G0150J |
| C204 | 281-0657-00 | B030000 | | CAP.,FXD,CER DI:13PF,2%,500V | 59660 | 374-018-C0G0130G |
| C208 | 283-0626-00 | | | CAP.,FXD,MICA D:1800PF,5%,500V | 00853 | D195F182J0 |
| C221 | 281-0114-00 | | | CAP.,VAR,AIR DI:1.3-5.4PF,750V | 74970 | 189-0752-075 |
| C229 | 281-0709-00 | | | CAP.,FXD,CER DI:7PF,+/-0.1PF,500V | 59660 | 374005C0H0709B |
| C250 | 281-0077-00 | | | CAP.,VAR,AIR DI:1.3-5.4PF,800V | 74970 | 189-0502-075 |
| C256 | 283-0003-00 | | | CAP.,FXD,CER DI:0.01UF,+80-20%,150V | 91418 | SP103Z151-4R9 |
| C259 | 283-0041-00 | | | CAP.,FXD,CER DI:0.0033UF,5%,500V | 72982 | 841-541B332J |
| C263 | 281-0540-00 | | | CAP.,FXD,CER DI:51PF,5%,500V | 59660 | 301-000U2J0510J |
| C279 | 281-0586-00 | | | CAP.,FXD,CER DI:25PF,5%,500V | 59660 | 302-000C0G0250J |
| C281 | 281-0534-00 | | | CAP.,FXD,CER DI:3.3PF,+/-0.25PF,500V | 04222 | 7001-1316 |
| C287 | 290-0134-00 | | | CAP.,FXD,ELCTLT:22UF,20%,15V | 56289 | 150D226X0015B2 |
| CR111 | 152-0324-00 | | | SEMICONV DEVICE:SILICON,35V,100MA | 03508 | DE103 |

ment. Complete adjustment instructions are given in Section 5 (Calibration).

5. Isolate Trouble to a Circuit

To isolate trouble to a particular circuit, note the trouble symptom. The symptom often identifies the circuit in which the trouble is located. When trouble symptoms appear in more than one circuit, check the affected circuits by taking voltage and waveform readings.

Incorrect operation of all circuits often indicates trouble in the oscilloscope system. It may be necessary to check first for the correct output of the oscilloscope mainframe power supplies.

6. Check Voltages and Waveforms

Often the defective component can be located by checking for the correct voltages or waveforms in the circuit. Typical voltages and waveforms are given in Section 8 (Diagrams and Circuit Board Illustrations).

NOTE

Voltages and waveforms given in Section 8, Diagrams and Circuit Board Illustrations, are not absolute and may vary slightly between instruments. To obtain operating conditions similar to those used to make these readings, see the voltage and waveform conditions on the schematic apron.

7. Check Individual Components

The following procedures describe methods of checking individual components. Components that are soldered in place are best checked by first disconnecting one end. This isolates the measurement from the effects of surrounding circuitry.

WARNING

To avoid electric shock, always disconnect the 5A21N from the power source before replacing components.

Fuses

Check for open fuses by checking the continuity with an ohmmeter. The locations of the fuses are shown on the Component Locator in Section 8.

Transistors

A good check of transistor operation is actual performance under operating conditions. A transistor can most effectively be checked by substituting a new component for it (or one which has been checked previously). However, be sure that circuit conditions are not such that a replacement transistor might also be damaged. If substitute transistors are not available, use a dynamic tester. Static-type testers are not recommended, since they do not check operation under simulated operating conditions.

Diodes

A diode can be checked for an open or shorted condition by measuring the resistance between terminals with an ohmmeter set on a scale having a low internal source current, such as the R X 1K scale. The resistance should be very high in one direction and very low when the meter leads are reversed.



When checking diodes, do not use an ohmmeter scale that has a high internal current, since high currents may damage the diodes under test.

Resistors

Check the resistors with an ohmmeter. Resistor tolerance is given in Section 7 (Replaceable Electrical Parts). Normally, resistors do not need to be replaced unless the measured value varies widely from the specified value.

Capacitors

A leaky or shorted capacitor can best be detected by checking resistance with an ohmmeter on the highest scale. Do not exceed the voltage rating of the capacitor. The resistance reading should be high after initial charge of the capacitor. An open capacitor can best be detected with a capacitance meter or by checking if the capacitor passes ac signals.

8. Repair and Readjust the Circuit

If any defective parts are located, follow the replacement procedures given under Component Replacement in this section. Check the performance of any circuit that has been repaired or that has had any electrical components replaced. Adjustment of the circuit may be necessary.

Replaceable Electrical Parts—5A21N

CROSS INDEX—MFR. CODE NUMBER TO MANUFACTURER

| Mfr. Code | Manufacturer | Address | City, State, Zip |
|-----------|---|--|-------------------------|
| 00853 | SANGAMO ELECTRIC CO., S. CAROLINA DIV. | P O BOX 128 | PICKENS, SC 29671 |
| 01121 | ALLEN-BRADLEY COMPANY | 1201 2ND STREET SOUTH | MILWAUKEE, WI 53204 |
| 01295 | TEXAS INSTRUMENTS, INC., SEMICONDUCTOR GROUP | P O BOX 5012, 13500 N CENTRAL EXPRESSWAY | DALLAS, TX 75222 |
| 03508 | GENERAL ELECTRIC COMPANY, SEMI-CONDUCTOR PRODUCTS DEPARTMENT | ELECTRONICS PARK | SYRACUSE, NY 13201 |
| 04222 | AVX CERAMICS, DIVISION OF AVX CORP. | P O BOX 867, 19TH AVE. SOUTH | MYRTLE BEACH, SC 29577 |
| 04713 | MOTOROLA, INC., SEMICONDUCTOR PROD. DIV. | 5005 E MCDOWELL RD, PO BOX 20923 | PHOENIX, AZ 85036 |
| 07263 | FAIRCHILD SEMICONDUCTOR, A DIV. OF FAIRCHILD CAMERA AND INSTRUMENT CORP. | 464 ELLIS STREET | MOUNTAIN VIEW, CA 94042 |
| 13511 | AMPHENOL CARDRE DIV., BUNKER RAMO CORP. | | LOS GATOS, CA 95030 |
| 24931 | SPECIALITY CONNECTOR CO., INC. | 2620 ENDRESS PLACE | GREENWOOD, IN 46142 |
| 32997 | BOURNS, INC., TRIMPOT PRODUCTS DIV. | 1200 COLUMBIA AVE. | RIVERSIDE, CA 92507 |
| 34263 | CTS OF BROWNSVILLE, INC. | 1100 ROOSEVELT ST. | BROWNSVILLE, TX 78520 |
| 53944 | ELT INC., GLOW LITE DIVISION | BOX 698 | PAULS VALLEY, OK 73075 |
| 55680 | NICHICON/AMERICA/CORP. | 6435 N PROESEL AVENUE | CHICAGO, IL 60645 |
| 56289 | SPRAGUE ELECTRIC CO. | 87 MARSHALL ST. | NORTH ADAMS, MA 01247 |
| 59660 | TUSONIX INC. | 2155 N FORBES BLVD | TUCSON, AZ 85705 |
| 71400 | BUSSMAN MFG., DIVISION OF MCGRAW-EDISON CO. | 2536 W. UNIVERSITY ST. | ST. LOUIS, MO 63107 |
| 71450 | CTS CORP. | 905 N. WEST BLVD | ELKHART, IN 46514 |
| 72982 | ERIE TECHNOLOGICAL PRODUCTS, INC. | 644 W. 12TH ST. | ERIE, PA 16512 |
| 73138 | BECKMAN INSTRUMENTS, INC., HELIPOT DIV. | 2500 HARBOR BLVD. | FULLERTON, CA 92634 |
| 74970 | JOHNSON, E. F., CO. | 299 10TH AVE. S. W. | WASECA, MN 56093 |
| 75042 | TRW ELECTRONIC COMPONENTS, IRC FIXED RESISTORS, PHILADELPHIA DIVISION | 401 N. BROAD ST. | PHILADELPHIA, PA 19108 |
| 76493 | BELL INDUSTRIES, INC., MILLER, J. W., DIV. | 19070 REYES AVE., P O BOX 5825 | COMPTON, CA 90224 |
| 80009 | TEKTRONIX, INC. | P O BOX 500 | BEAVERTON, OR 97077 |
| 91418 | RADIO MATERIALS COMPANY, DIV. OF P.R. MALLORY AND COMPANY, INC. | 4242 W BRYN MAWR | CHICAGO, IL 60646 |
| 91637 | DALE ELECTRONICS, INC. | P. O. BOX 609 | COLUMBUS, NE 68601 |
| 92966 | SYLVANIA MINIATURE LIGHTING PRODUCTS, INC., SUB OF GTE SYLVANIA, LIGHT. PROD. | 526 ELM STREET | KEARNY, NJ 07032 |

CORRECTIVE MAINTENANCE

Corrective maintenance consists of component replacement and instrument repair. Special techniques required to replace components are given here.

OBTAINING REPLACEMENT PARTS

Most electrical and mechanical parts can be obtained through your local Tektronix Field Office or representative. However, many of the standard electronic components can be obtained locally. Before ordering or purchasing a part from a source other than Tektronix, Inc., check the electrical parts list for the proper value, tolerance, rating, and description.

Some parts are manufactured or selected by Tektronix, Inc. to satisfy particular requirements, or are manufactured for Tektronix, Inc. to our specifications.

NOTE

When selecting replacement parts, remember that the physical size and shape of a component may affect its performance in the instrument. All replacement parts should be direct replacements unless you know that a different component will not adversely affect instrument performance.

Most of the mechanical parts used in this instrument have been manufactured by Tektronix, Inc. To determine manufacturer of parts, refer to Parts List, Cross Index Mfr. Code Number to Manufacturer.

When ordering replacement parts from Tektronix, Inc. include the following information:

1. Instrument type.
2. Instrument serial number.
3. A description of the part (if electrical, include the circuit number, if crt, also include all data on crt tag).
4. Tektronix part number.

SOLDERING TECHNIQUES

WARNING

To avoid electric shock, disconnect the instrument from the power source before soldering.

The reliability and accuracy of this instrument can be maintained only if proper soldering techniques are used when repairing or replacing parts. General soldering should be used when working on this instrument. Use only 60/40 rosin-core, electric-grade solder. The choice of soldering iron is determined by the repair to be made. When soldering on circuit boards or small wiring, use only a 15-watt, pencil-type soldering iron. A higher wattage soldering iron can cause the etched circuit run to separate from the board base material and melt the insulation from small wiring. Always keep the soldering-iron tip properly tinned to ensure the best heat transfer to the solder joint. Apply only enough heat to remove the component or to make a good solder joint. To protect heat-sensitive components, hold the component lead between the component body and the solder joint with a pair of long-nose pliers or an alligator clip. Use a solder-removing wick to remove excess solder from connections or to clean circuit board pads.

The following technique should be used to replace a component on any of the circuit boards in this instrument. Most components can be replaced without removing the board from the instrument.

1. Touch the soldering iron to the lead at the solder connection. Never place the iron directly on the board, as this may damage the board.

2. Melt a small amount of solder onto the component lead connection. This replaces the flux, which may have been removed during instrument cleaning, and facilitates removal of the component.

3. Grip the component lead with a pair of long-nose pliers. When the solder begins to flow, gently pull the component lead from the board. If unable to separate the lead from the board, try removing the other end of the component.

NOTE

Some components are difficult to remove from the circuit board due to a bend placed in each lead during machine insertion of the component. The purpose of the bent leads is to hold the component in position during a flow-solder manufacturing process which solders all components at once. To make removal of machine inserted components easier, straighten the leads of the component on the back of the circuit board using a small screwdriver or pliers, while heating the soldered connection.

REPLACEABLE ELECTRICAL PARTS

PARTS ORDERING INFORMATION

Replacement parts are available from or through your local Tektronix, Inc. Field Office or representative.

Changes to Tektronix instruments are sometimes made to accommodate improved components as they become available, and to give you the benefit of the latest circuit improvements developed in our engineering department. It is therefore important, when ordering parts, to include the following information in your order: Part number, instrument type or number, serial number, and modification number if applicable.

If a part you have ordered has been replaced with a new or improved part, your local Tektronix, Inc. Field Office or representative will contact you concerning any change in part number.

Change information, if any, is located at the rear of this manual.

LIST OF ASSEMBLIES

A list of assemblies can be found at the beginning of the Electrical Parts List. The assemblies are listed in numerical order. When the complete component number of a part is known, this list will identify the assembly in which the part is located.

CROSS INDEX-MFR. CODE NUMBER TO MANUFACTURER

The Mfr. Code Number to Manufacturer index for the Electrical Parts List is located immediately after this page. The Cross Index provides codes, names and addresses of manufacturers of components listed in the Electrical Parts List.

ABBREVIATIONS

Abbreviations conform to American National Standard Y1.1.

COMPONENT NUMBER (column one of the Electrical Parts List)

A numbering method has been used to identify assemblies, subassemblies and parts. Examples of this numbering method and typical expansions are illustrated by the following:

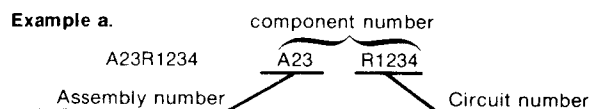

Read: Resistor 1234 of Assembly 23

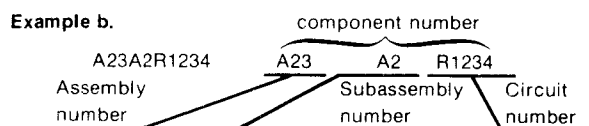

Read: Resistor 1234 of Subassembly 2 of Assembly 23

Only the circuit number will appear on the diagrams and circuit board illustrations. Each diagram and circuit board illustration is clearly marked with the assembly number. Assembly numbers are also marked on the mechanical exploded views located in the Mechanical Parts List. The component number is obtained by adding the assembly number prefix to the circuit number.

The Electrical Parts List is divided and arranged by assemblies in numerical sequence (e.g., assembly A1 with its subassemblies and parts, precedes assembly A2 with its subassemblies and parts).

Chassis-mounted parts have no assembly number prefix and are located at the end of the Electrical Parts List.

TEKTRONIX PART NO. (column two of the Electrical Parts List)

Indicates part number to be used when ordering replacement part from Tektronix.

SERIAL/MODEL NO. (columns three and four of the Electrical Parts List)

Column three (3) indicates the serial number at which the part was first used. Column four (4) indicates the serial number at which the part was removed. No serial number entered indicates part is good for all serial numbers.

NAME & DESCRIPTION (column five of the Electrical Parts List)

In the Parts List, an Item Name is separated from the description by a colon (:). Because of space limitations, an Item Name may sometimes appear as incomplete. For further Item Name identification, the U.S. Federal Cataloging Handbook H6-1 can be utilized where possible.

MFR. CODE (column six of the Electrical Parts List)

Indicates the code number of the actual manufacturer of the part. (Code to name and address cross reference can be found immediately after this page.)

MFR. PART NUMBER (column seven of the Electrical Parts List)

Indicates actual manufacturers part number.

4. Bend the leads of the replacement component to fit the holes in the circuit board. If the component is replaced while the board is mounted in the instrument, cut the leads so they will just protrude through the board. Insert the leads into the holes in the board so that the component is firmly seated against the board, or as originally positioned.

5. Touch the iron to the connection and apply enough solder to make a firm solder joint.

6. Cut off any excess lead protruding through the board (if not clipped in step 4).

7. Clean the area around the solder connection with a flux-removing solvent. Be careful not to remove information printed on the circuit board.

COMPONENT REMOVAL AND REPLACEMENT

WARNING

To avoid electric shock, always disconnect the 5A21N from the power source before replacing components.

The exploded-view drawings associated with the Replaceable Mechanical Parts list (located at the rear of this manual) may be helpful in the removal or disassembly of individual components.

Circuit Board Replacement

If the circuit board is damaged beyond repair, the entire assembly, including all soldered-on components, can be replaced. Part numbers for the completely wired board is given in Section 7 (Replaceable Electrical Parts).

A1 Main Board Removal

Remove the A1 Main circuit board as follows:

1. Remove the VOLTS/DIV and CAL control knobs. This requires a 1/16-inch Allen wrench to loosen the set screw in each knob.

2. Disconnect the DISPLAY ON and BANDWIDTH LIMIT control extension shafts at the switches (insert a scribe or small screwdriver between the end of the white plastic switch-shaft and the inside end of the black plastic extension-shaft and pry gently).

3. Remove the ATTEN STEP BAL control knob and extension shaft. This requires a 0.050-inch Allen wrench to loosen the front setscrew in the flexible coupling.

4. Pull the input coupling pushbuttons from the switch shafts.

5. Unsolder all wires at the circuit board that come from the front-panel controls, input capacitors, connectors and lamps. Record the color-coding of each wire and its point of attachment to aid in board installation. Another installation aid is to make notes on the Component Locator diagram (located in Section 8), marking appropriately as the wires are unsoldered.

6. Remove four screws that mount the board to the chassis bent tabs.

7. Slide the circuit board to the rear of chassis, using care to prevent damage to any of the components as the board is removed.

To install the circuit-board, reverse the removal procedure.

SEMICONDUCTOR REPLACEMENT

Semiconductors should not be replaced unless actually defective. If removed from their sockets during routine maintenance, return them to their original sockets. Unnecessary replacement of semiconductors may affect the adjustment of the instrument. When semiconductors are replaced, check the operation of circuits that may be affected.

WARNING

Always disconnect the 5A21N from the power source before replacing components to avoid electrical-shock hazard.

Replacement semiconductors should be of the original type or a direct replacement. Lead configurations of the semiconductors used in this instrument are shown in Fig. 4-2. Some plastic case transistors have lead configurations that do not agree with those shown. If a replacement transistor is made by a different manufacturer than the original, check the manufacturer's basing diagram for correct basing. All transistor sockets are wired for the standard basing as used for metal-cased transistors.

CAM SWITCH REPLACEMENT AND LUBRICATION

Two types of switches are used in this instrument, cam and push-button switches. Contact alignment and spacing are critical to the operation of these switches. Therefore, defective switches should either be replaced by replacing the complete board or repaired only by personnel experienced with these types of switches. Your local Tektronix Field Office or representative can provide additional repair information. The following special maintenance information is provided for cam switch replacement.

Cam switches consist of a rotating cam that mates with contacts on the adjacent circuit board. These contacts are activated by lobes on the cam as the switch is rotated. A cam switch can be disassembled for inspection, cleaning, repair, or replacement; however, it is recommended that the switch and circuit board be replaced as a unit.

CAUTION

Cam switch repair should be undertaken only by experienced maintenance personnel. Switch alignment and contact spacing must be carefully maintained for proper operation. A cam switch repair kit is available from Tektronix which contains special alignment tools for use in repairing or replacing the switch contacts. For information or assistance on maintenance of cam switches, contact your local Tektronix Field Office or representative.

Generally, there are no components in this instrument that require a regular lubrication program during the life of the instrument. The cam switch is lubricated at the factory and should be adequate for the life of the instrument. However, if the switch has been disassembled for replacement of switch sub-parts or cleaning, and lubrication is desired, a lubrication kit containing the necessary lubricating materials and instructions is available through any Tektronix Field Office. General Electric Versilube® is a recommended silicone grease and should be applied sparingly so that the lubricant does not get on the contacts. Refer to Fig. 4-3 for lubrication instructions.

OPTIONAL HIGH IMPEDANCE INPUT (A USER MODIFICATION)

In the 50 mV through 50 μ V positions of the VOLTS/DIV switch, where the input attenuator is not used, the internal

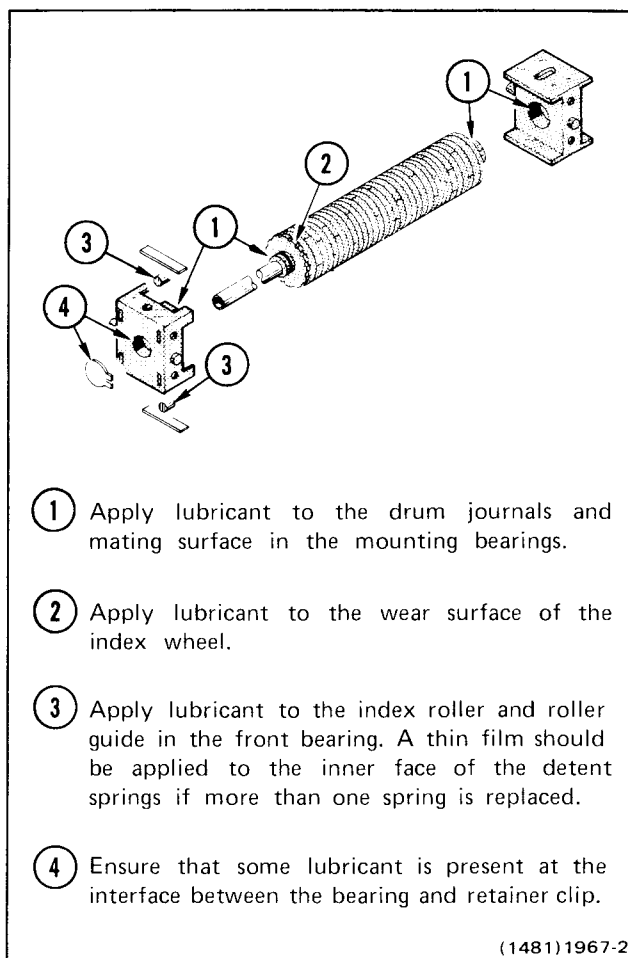

Fig. 4-3. Lubrication procedure for a typical cam switch.

gate return resistors alone establish the 1 M Ω input resistance. The removal of a strap from the circuit board disconnects these resistors from ground and permits the input FET gates to float, providing a very high input impedance.

If a high impedance input is desired, see Fig. 5-1 in the Calibration section for the location of the wire strap that enables a high-impedance input with that strap removed. Disconnect one end of the strap to make an appropriate electrical removal. When this change is made, the instrument front panel should be marked appropriately to alert the user to the high-impedance input. The strap must be added (connected back in) before performing any of the procedures in Section 5 (Calibration). If the impedance change is intended to be a permanent change, it is recommended that you provide complete documentation on the change and attach it to the instrument. This is important if the instrument should ever need to be sent to a Tektronix Service Center for repair and calibration.

INSTRUMENT OPTIONS

Your instrument may be equipped with one or more options. A brief description of each available option is given in this section.

Option 01

The 5A21N Option 01 instrument includes a P6021 passive ac current probe that permits current waveforms to be viewed and measured on the 5A21N Amplifier-oscilloscope system. Section 1—General Information in this manual contains specification information relating to the 5A21N current probe input only. See the P6021 Current Probe manual for all other probe details.

OPTIONAL BANDWIDTH LIMITING FREQUENCIES (A USER MODIFICATION)

In some applications, it may be desirable to change the upper bandwidth frequency limit to some other value than the two limits selectable at the front panel of the 5A21N (1 MHz and 10 kHz). The 10 kHz upper frequency limit (selected by the BANDWIDTH LIMIT push button) may be altered by changing internal capacitor C259. Frequency limits other than 10 kHz that can be obtained with common capacitor values are, for example: 300 kHz, 100 kHz, 30 kHz or 3 kHz. If a bandwidth limit frequency change is desired, remove C259 from the circuit board (see Fig. 5-1 in the Calibration section for location of the capacitor). Table 4-1 lists some typical upper bandwidth limits and the appropriate capacitor values for each limit. Select the capacitor value recommended for the desired upper bandwidth limit and install the capacitor in the C259 position. The capacitor used should be non-polarized and have a working dc voltage of at least 100 volts.

Table 4-1

OPTIONAL BANDWIDTH LIMITING

| Upper Bandwidth Limit (-3 dB) | Capacitor Value |
|----------------------------------|--------------------|
| 300 kHz | 82 pF |
| 100 kHz | 304 pF |
| 30 kHz | 0.001 μ F |
| 3 kHz | 0.01 μ F |

When a frequency change has been accomplished, the instrument front panel should have the frequency change marked on it as a reminder to the user. The original capacitor should be saved and installed again before performing any of the procedures in Section 5, Calibration. If a frequency change is intended to be a permanent change, it is recommended that you provide complete documentation on the change and attach it to the instrument. This is important if the instrument should ever need to be sent to a Tektronix Service Center for repair and calibration.

ADJUSTMENT AFTER REPAIR

After any electrical component has been replaced, the adjustment of that particular circuit should be checked, as well as the adjustment of any closely related circuits. See Section 5 (Calibration) in this manual for a complete adjustment procedure.

Calibration—5A21N

b. Set the standard amplitude calibrator for a 5 mA output at the current loop of the generator.

c. Connect a 125-turn current probe (P6021) to the 125 TURN PROBE input connector and connect the probe tip to the 5 mA current loop of the standard amplitude calibrator. Adjust the Triggering Level control for a stable display.

d. CHECK—Five divisions, $\pm 3\%$, of vertical display.

11. Check Current Probe Amplifier Frequency Response

a. Connect a GR-to-bnc male adapter to the sine-wave generator output. Connect a high-frequency current test fixture to the adapter. Connect the 125-turn current probe to the test fixture.

b. Change the time-base Seconds/Div switch to .5 ms.

c. Adjust the sine-wave generator for eight vertical divisions of 1 kHz display as a reference. Then slowly increase the frequency until the display amplitude is 5.66 divisions. This is the upper -3 dB point.

d. CHECK—Frequency is at least 1 MHz.

e. Set the BANDWIDTH LIMIT to 10 kHz (button in) and adjust the sine-wave generator for eight vertical divisions of 2 kHz reference display. Then slowly increase the frequency until the display amplitude is 5.66 divisions.

f. CHECK—Frequency at the upper -3 dB point (bandwidth limited) is between 8 kHz and 12 kHz.

g. Release the BANDWIDTH LIMIT switch (button out) and adjust the sine-wave generator for eight vertical divisions of 2 kHz reference display. Then slowly decrease the frequency until the display amplitude is 5.66 divisions. This is the lower -3 dB point. Set the time-base Seconds/Div switch as necessary to view the signal.

h. CHECK—Frequency is 15 Hz or less.

i. Disconnect all test equipment.

This completes the Part II—Adjustment and Performance Check procedure.

- b. Connect a 50 Ω termination to the + input connector and using the ATTEN STEP BAL control, position the trace to the graticule centerline.
- c. Release the GND button of the + Input Coupling switch (input AC-coupled) and allow a few seconds for the display to stabilize.
- d. CHECK—Trace shift is less than ± 2 divisions. This indicates an input gate current of 100 pA or less.
- e. Ground the + Input Coupling (GND button in) and move the 50 Ω termination to the - input connector.
- f. Release the GND button of the - Input Coupling switch.
- g. CHECK—Trace shift is less than ± 2 divisions.
- h. Remove the 50 Ω termination, release the GND button of the + Input Coupling switch, and position the display to graticule center (both the + and - Input Coupling switches should be set to AC and ungrounded).
- i. Set the standard amplitude calibrator for a 5 V dc output (see the instruction manual for the amplitude calibrator to convert to dc output).
- j. Connect the standard amplitude calibrator output connector to the + input connector through a coaxial cable and allow at least 10 seconds for the display to stabilize.
- k. CHECK—Trace shift is ± 1 division or less. This indicates an input dc rejection ratio of 100,000:1.
- l. Move the cable to the - input and allow the display to stabilize.
- m. CHECK—Trace shift is ± 1 division or less.
- n. Disconnect the coaxial cable and return the standard amplitude calibrator to square-wave output operation.

9. Check Overall Noise Level Tangentially

- a. Connect the standard amplitude calibrator output directly to a GR-to-bnc male adapter, then connect a

variable attenuator (with arrow on variable attenuator pointing away from the calibrator output). Connect also in sequence to the signal setup, a GR-to-bnc female adapter, a coaxial cable, two 10X attenuators, a 50 Ω termination, then to the + input connector.

- b. Set the standard amplitude calibrator for a 0.1 V square-wave output and turn the variable attenuator control fully clockwise.

- c. Change the following control settings:

| | |
|---------------------------------|------------------------------------|
| VOLTS/DIV | 50 μ V |
| BANDWIDTH LIMIT | 1 MHz (button out) |
| + Input Coupling | DC |
| - Input Coupling | GND |
| Seconds/Div (time-base) | .5 ms |
| Triggering Level (time base) | Clockwise (untriggered display) |

- d. Turn the variable attenuator control slowly counterclockwise and observe two noise bands displayed on the crt (noise and free-running square wave). Continue to turn the variable attenuator control until the two noise bands merge (just to the point at which the dark band between the two noise bands disappears).

- e. Remove the two 10X attenuators and connect the variable attenuator directly to the 50 Ω termination.

- f. Switch the VOLTS/DIV switch to any position that will give a convenient display (two traces).

- g. CHECK—The vertical amplitude of the display. Calculate the tangentially measured noise by dividing the measured display by 100. For example, two divisions of display at 0.5 mV per division is equal to one millivolt. One millivolt divided by 100 is equal to 10 μ V of tangentially measured noise. Maximum noise, 30 μ V.

- h. Disconnect all test equipment.

10. Check Current Probe Amplifier Gain

- a. Change the control settings as follows:

| | |
|----------------------------|--------------------------------|
| Volts-Amperes Mode | CURR PROBE ONLY (button in) |
| AMPERES/DIV | 1 mA |
| Seconds/Div (time-base) | 1 ms |

CALIBRATION

This section provides procedures for calibrating this instrument. These procedures are designed to compare the performance of this instrument with measurement instruments of known accuracy to detect, correlate, or eliminate by adjustment, any variation from the electrical specifications. These procedures also verify that the controls function properly.

This section is divided into two parts: Part I—Performance Check is provided for those who wish to verify that this instrument meets the applicable electrical specifications in section 1 without making internal adjustments. Part II—Adjustment and Performance Check provides a complete calibration procedure that includes adjustments and performance checks in addition to verifying that the controls function properly.

Table 5-1 (Calibration Procedure Electives) lists the choices available and instructions for performing complete or partial calibration procedures. Also refer to the subject heading, Using These Procedures, for more detailed information.

USING THESE PROCEDURES

These procedures check the 5A21N for measurement accuracy against the tolerances listed as Performance Requirements that appear in Table 1-1 (Electrical

Characteristics) in Section 1—General Information. If the instrument fails to meet the requirements given in the performance checks, the corresponding adjustment should be performed as directed in Part II—Adjustment and Performance Check procedure.

The Electrical Characteristics in this section are valid only if the oscilloscope has been calibrated at an ambient temperature between +20° C to +30° C and is operating at an ambient temperature between 0° C to +50° C.

Tolerances that are specified in these procedures apply to the instrument under test and do not include test equipment error. Limits and tolerances in this procedure are instrument performance requirements only if listed in the Performance Requirements column that appears in Table 1-1 (Electrical Characteristics) in Section 1; information given in the Supplemental Information column of that table is provided for user information only, and should not be interpreted as performance requirements.

In these procedures, capital letters are used within the body of the text to identify front-panel controls, indicators, and connectors of the 5A21N (e.g., VOLTS/DIV). Initial capitalization is used to identify all the associated test equipment and their controls, indicators, and connectors (e.g., Amplitude) used in the procedures. Initial capitalization is also used to identify internal adjustments of the 5A21N (e.g., Low Freq CMRR).

Table 5-1

CALIBRATION PROCEDURE ELECTIVES

| Electives | Procedures |
|------------------------|--|
| Functional Check | 1. A functional check only is provided in the Checkout Procedure in section 2. 2. A functional check is also accomplished by performing Part II—Adjustment and Performance Check. |
| Performance Check Only | Perform Part I—Performance Check. |
| Complete Calibration | Perform Part II—Adjustment and Performance Check. |
| Partial Procedures | Proceed to the desired step(s) listed in the index to Part I—Performance Check or Index to Part II—Adjustment and Performance Check. |

Calibration—5A21N

i. CHECK—The display for four divisions or less of 100 Hz signal (disregard trace noise).

j. Change the sine-wave generator frequency to 1 kHz.

k. CHECK—The display for four divisions or less of 1 kHz signal (disregard trace noise).

6. Check/Adjust High-Frequency CMRR (C221, C250)

a. Set the sine-wave generator for a 20 V, 30 kHz output (set the VOLTS/DIV switch to 5 V, – Input Coupling to GND and obtain four vertical divisions of display).

b. Set the – Input Coupling to DC and the VOLTS/DIV switch to 50 mV. Set the time base Seconds/Div switch to 1 ms.

c. CHECK—Vertical deflection for all VOLTS/DIV switch ranges from 50 mV to .1 mV is two divisions or less; for 50 μ V, four divisions or less.

d. If more than two divisions of vertical display is present at these ranges and adjustment is to be made, set the VOLTS/DIV switch to .1 mV.

e. ADJUST—C221, CMRR 2, for minimum vertical deflection (must be two divisions or less). See Fig. 5-1 for adjustment location.

f. ADJUST—C250, CMRR 1, for minimum display amplitude on each setting when switching the VOLTS/DIV over the range of 1 mV to 50 mV. See Fig. 5-1 for adjustment location.

g. CHECK—Vertical deflection for all VOLTS/DIV switch ranges from .1 mV to 50 mV is two divisions or less.

h. INTERACTION—Between the two CMRR adjustments may be critical. Adjust CMRR 1 and CMRR 2 for best compromise if necessary.

i. Disconnect all test equipment.

NOTE

This completes the adjustment portion of the Part II—Adjustment and Performance Check Procedure. Continue the procedure for the remainder of the performance checks.

7. Check Amplifier Bandwidth

a. Set the sine-wave generator for minimum output amplitude and connect the generator output to the + input connector through a coaxial cable.

b. Change the controls as follows:

| | |
|-------------------------|-------|
| VOLTS/DIV | .1 V |
| + Input Coupling | AC |
| – Input Coupling | GND |
| Seconds/Div (time-base) | .5 ms |

c. Adjust the sine-wave generator for eight vertical divisions of 1 kHz display as a reference. Then slowly increase the frequency until the display amplitude is 5.66 divisions. This is the upper –3 dB point.

d. CHECK—Frequency at the upper –3 dB point must be at least 1 MHz.

e. Set the BANDWIDTH LIMIT to 10 kHz (button in) and adjust the sine-wave generator for eight vertical divisions of 2 kHz reference display. Then slowly increase the frequency until the display is 5.66 divisions.

f. CHECK—Frequency at the upper –3 dB point (bandwidth limited) is between 8 kHz and 12 kHz.

g. Release the BANDWIDTH LIMIT switch (button out) and adjust the sine-wave generator for eight vertical divisions of 2 kHz reference display. Then slowly decrease the frequency until the display amplitude is 5.66 divisions. This is the lower –3 dB point when AC coupling is used (determined by the coupling capacitor). Set the time-base Seconds/Div as necessary to view the signal.

h. CHECK—Frequency at the lower –3 dB point is 2 Hz or less.

i. Disconnect the sine-wave generator.

8. Check Input Gate Current and DC Rejection

a. Position the trace to the graticule center, then change the following control settings:

| | |
|-------------------------|------------|
| BANDWIDTH LIMIT | 10 kHz |
| VOLTS/DIV | 50 μ V |
| + Input Coupling | AC, GND |
| – Input Coupling | AC, GND |
| Seconds/Div (time-base) | 1 ms |

Calibration—5A21N

The terms CHECK, EXAMINE, ADJUST, or INTERACTION when used as the first word of an instruction are defined as follows:

1. CHECK—indicates the instruction accomplishes an electrical specification check. Each electrical specification checked is listed in Table 5-2, Performance Check Summary (see the Performance Check Summary discussion for more information).

2. EXAMINE—usually precedes an ADJUST instruction and indicates that the instruction determines whether adjustment is necessary. If no ADJUST instruction appears in the same step, the EXAMINE instruction concerns measurement limits that do not have a related adjustment. Measurement limits following the word EXAMINE are not to be interpreted as electrical specifications. They are provided as indicators of a properly functioning instrument and to aid in the adjustment process.

3. ADJUST—describes which adjustment to make and the desired result. We recommend that adjustments not be

made if a previous CHECK or EXAMINE instruction indicates that no adjustment is necessary.

4. INTERACTION—indicates that the adjustment described in the preceding instruction interacts with another adjustment, an electrical specification check, or other circuits. The nature of the interaction is described and reference is made to any adjustment or check affected.

Performance Check Summary

Table 5-2 (Performance Check Summary) lists the electrical specifications that are checked in Part I and Part II of this section. Table 5-2 is intended to provide a convenient means for locating the procedures in Part I and Part II that check and/or adjust the instrument to meet the applicable electrical specifications. For example: if the Output Amplifier had been repaired, use Table 5-2 to locate the electrical specifications affected by the repair. Then, note the step number of the procedure in Part I or Part II in which those specifications are checked and/or adjusted. Use the index provided at the front of Part I and Part II to determine the page number of the desired procedures.

**Table 5-2
PERFORMANCE CHECK SUMMARY**

| Characteristic | Performance Requirement | Part I Performance Check Procedure Step | Part II Adjustment and Performance Check Procedure Step |
|-----------------------|--------------------------------|---|---|
| Deflection Factor | | | |
| VOLTS/DIV | | | |
| Calibrated Range | 50 μ V/div to 5 V/div. | Step 3. Check Amplifier Gain and VOLTS/DIV Switch Accuracy. | Step 3. Check/Adjust Amplifier Gain (R268) and check VOLTS/DIV Switch Accuracy. |
| Accuracy | Within 2%. | | |
| AMPERES/DIV | | | |
| Calibrated Range | 0.5 mA/div to 0.5 A/div. | (Satisfactory operation is substantiated by performing Steps 3 and 10.) | (Satisfactory operation is substantiated by performing Steps 3 and 10.) |
| Accuracy | Within 3%. | Step 10. Check Current Probe Amplifier Gain. | Step 10. Check Current Probe Amplifier Gain. |

Table 5-5
VOLTS/DIVISION ACCURACY

| VOLTS/DIV Switch Setting | Standard Amplitude Calibrator Output | CRT Display (Vertical Deflection) |
|--------------------------------|---|--------------------------------------|
| 5 V | 20 volts | 4 div, ± 0.08 div |
| 2 V | 10 volts | 5 div, ± 0.1 div |
| 1 V | 5 volts | 5 div, ± 0.1 div |
| .5 V | 2 volts | 4 div, ± 0.08 div |
| .2 V | 1 volt | 5 div, ± 0.1 div |
| .1 V | .5 volt | 5 div, ± 0.1 div |
| 50 mV | .2 volt | 4 div, ± 0.08 div |
| 20 mV | .1 volt | 5 div, ± 0.1 div |
| 10 mV | 50 mV | 5 div, ± 0.1 div |

Connect a 1000:1 divider between the calibrator output and the + input connector to check higher sensitivity ranges.

| | | |
|------------|------|-----------------------|
| 5 mV | 20 V | 4 div, ± 0.08 div |
| 2 mV | 10 V | 5 div, ± 0.1 div |
| 1 mV | 5 V | 5 div, ± 0.1 div |
| .5 mV | 2 V | 4 div, ± 0.08 div |
| .2 mV | 1 V | 5 div, ± 0.1 div |
| .1 mV | .5 V | 5 div, ± 0.1 div |
| 50 μ V | .2 V | 4 div, ± 0.08 div |

h. Move the RC normalizer, termination and cable setup from the + input to the - input.

i. Set the + Input Coupling to GND and - Input Coupling to DC. Position the display to the center of the graticule area.

j. Set the VOLTS/DIV switch to .1 V and set the standard amplitude calibrator for a five-division display.

k. CHECK—Optimum square leading corner at bottom of the square-wave display. Aberrations are not to exceed + or - 2%, or 3% total.

l. ADJUST—C11 and C12, - Input Comp, for minimum roll-off or overshoot at bottom leading corner of square-wave display. See Fig. 5-1 for adjustment locations.

m. Change the VOLTS/DIV switch to 50 mV and adjust the standard amplitude calibrator for a five-division display.

n. CHECK—Optimum square leading corner at bottom of the square-wave display. Aberrations are not to exceed + or - 2%, or 3% total.

o. ADJUST—C13, - Input Comp. for minimum roll-off or overshoot at bottom leading corner of square-wave display. See Fig. 5-1 for adjustment location.

p. Disconnect the RC normalizer and standard amplitude calibrator setup.

5. Check/Adjust Low-Frequency CMRR (R109)

a. Set the controls as follows:

| | |
|-------------------------|------|
| VOLTS/DIV | 5 V |
| + Input Coupling | DC |
| - Input Coupling | GND |
| Seconds/Div (time-base) | 5 ms |

b. Connect a dual input cable to the + and - input connectors. Connect a sine-wave generator output to the dual-input cable through a coaxial cable.

c. Set the sine-wave generator for a 100 hz, 20 V peak-to-peak reference signal (set to obtain four divisions of vertical deflection).

d. Set the - Input Coupling to DC (both the + and - Input Coupling switches should now be set to DC, ungrounded) and set the VOLTS/DIV switch to .1 V.

e. CHECK—For a vertical deflection of 0.5 division or less.

NOTE

A displayed signal of 50 mV (0.5 division) or less, of a 20 V signal, indicates that CMRR is at least 400:1 (52 dB).

f. ADJUST—R109, Low-Freq CMRR, for minimum deflection. See Fig. 5-1 for adjustment location.

g. Set the sine-wave generator for a 1 kHz, 20 V output signal and check for a vertical deflection of 0.5 division or less. Readjust R109, Low-Freq CMRR, if necessary for best compromise at 100 Hz and 1 kHz.

h. Set the sine-wave generator for a 100 Hz, 20 V signal and set the VOLTS/DIV switch to 50 μ V.

Table 5-2 (cont)

| Characteristic | Performance Requirement | Part I Performance Check Procedure Step | Part II Adjustment and Performance Check Procedure Step |
|--|--|---|--|
| Frequency Response Bandwidth (8 Div Reference) DC (Direct) Coupled 1 MHz 10 kHz AC (Capacitive) Coupled 1 MHz 10 kHz | Dc to at least 1 MHz. Dc to ≈10 kHz. 2 Hz or less to at least 1 MHz. 2 Hz or less to ≈10 kHz. | Step 7. Check Amplifier Bandwidth. | Step 7. Check Amplifier Bandwidth. |
| AMPERES Mode 1 MHz 10 kHz | 15 Hz or less to at least 1 MHz. 15 Hz or less to ≈10 kHz. | Step 11. Check Current Probe Amplifier Frequency Response. | Step 11. Check Current Probe Amplifier Frequency Response. |
| Step Response (Dis- played) Aberrations | +2%, -2% or less, total of 3% or less of pulse amplitude. | Step 4. Check Input Compensation. | Step 4. Check/Adjust Input Compensation. |
| Inputs Voltage Mode Resistance Capacitance | 1 MΩ within 0.14%. ≈47 pF. | Step 4. Check Input Compensation. | Step 4. Check/Adjust Input Compensation. |
| Maximum Safe Input Voltages DC (Direct) Coupled 50 μV/div to 50 mV/div 100 mV/div to 5 V/div AC (Capacitive) Coupled 50 μV/div to 50 mV/div 100 mV/div to 5 V/div | 10 V (DC + Peak AC) 350 V (DC + Peak AC) 350 V DC (Coupling cap- acitor precharged), 10 V peak AC. 350 V (DC + Peak AC) | Specification applicable under fault conditions; therefore this is not a procedural check. | |

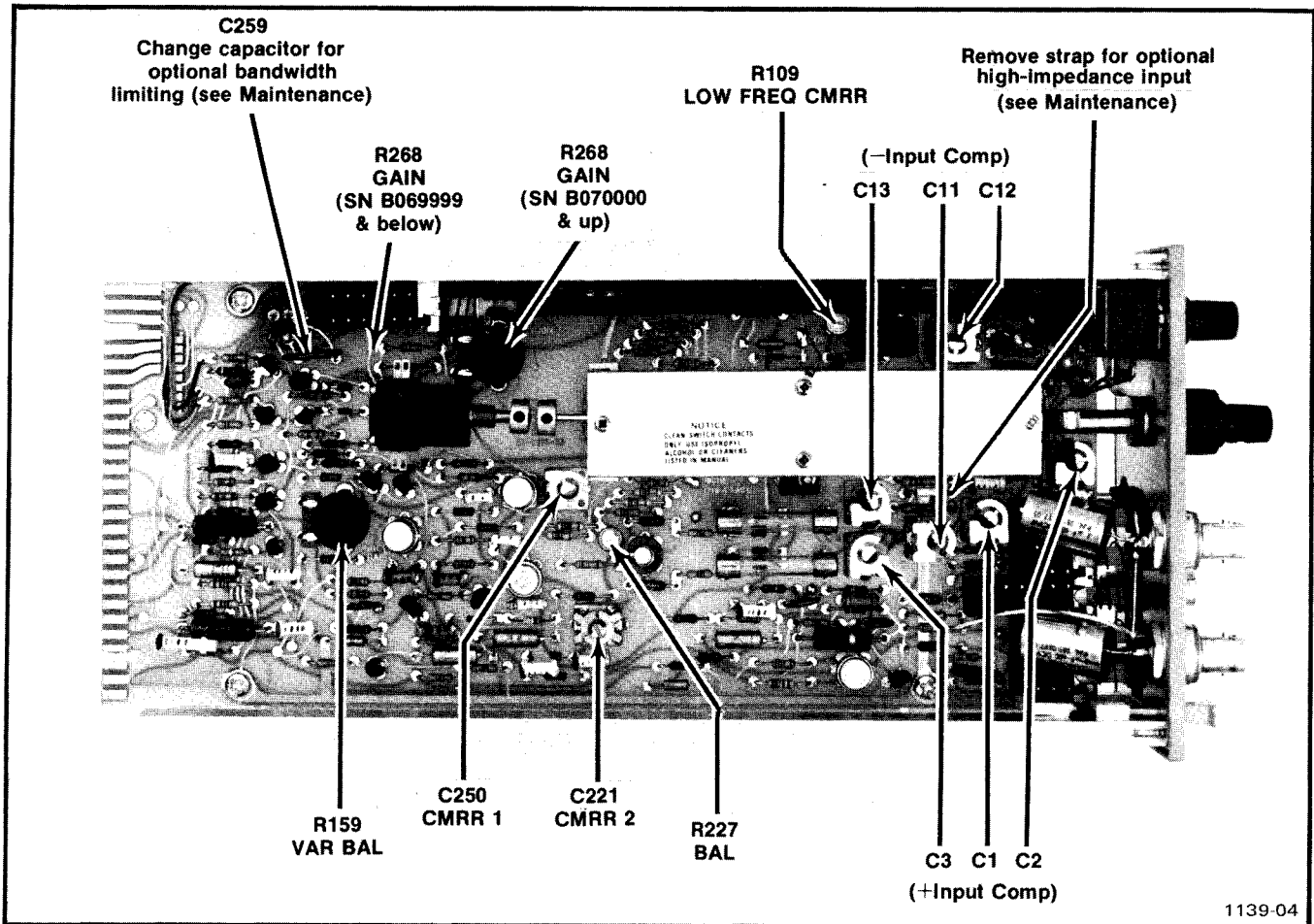

Fig. 5-1. Adjustment locations.

h. CHECK—Using the VOLTS/DIV switch and standard amplitude calibrator switch settings given in Table 5-5, check the VOLTS/DIV switch accuracy. Set the BANDWIDTH LIMIT switch to 10 kHz for the more sensitive positions.

i. Remove the 1000:1 divider and coaxial cable.

4. Check/Adjust Input Compensation (C1, C2, C3, C11, C12, C13)

a. Connect a 47 pF input RC normalizer to the + input connector, then connect a 50 Ω termination between the normalizer and signal cable. Set the VOLTS/DIV switch to .1 V and the BANDWIDTH LIMIT to 1 MHz (button out).

b. Set the standard amplitude calibrator for a five-division display of a fast-risetime, 1 kHz square-wave signal.

c. CHECK—Optimum square leading corner at top of the square-wave display. Aberrations are not to exceed + or - 2%, or 3% total (peak-to-peak).

d. ADJUST—C1 and C2, + Input Comp, for minimum roll-off or overshoot at top leading corner of square-wave display. See Fig. 5-1 for adjustment locations.

e. Change the VOLTS/DIV switch to 50 mV and adjust the standard amplitude calibrator for a five-division display.

f. CHECK—Optimum square leading corner of the square-wave display. Aberrations are not to exceed + or - 2%, or 3% total.

g. ADJUST—C3, + Input Comp, for minimum roll-off or overshoot at top leading corner of square-wave display. See Fig. 5-1 for adjustment location.

Table 5-2 (cont)

| Characteristic | Performance Requirement | Part I Performance Check Procedure Step | Part II Adjustment and Performance Check Procedure Step |
|---|--|---|--|
| DC Rejection, AC (Capacitive) Coupled | At least 100,000:1 after 20 minute warmup. | Step 8. Check Input Gate Current and DC Rejection. | Step 8. Check Input Gate Current and DC Rejection. |
| Input Gate Current | 100 pA or less (equivalent to 100 μ V or less, depend- ing on external loading) at 25°C. | | |
| Current Mode Maximum Equivalent Input | 4 A peak-to-peak (at probe tip) with 125-turn current probe. | Customer verification normally not required. | |
| Common Mode Rejection DC (Direct) Coupled | At least 100,000:1 (100 dB) DC to 30 kHz at 50 μ V/div and 0.1 mV/div with up to 20 V peak-to-peak sine wave, decreasing by less than 20 dB/decade on lower sensitivity ranges up to 50 mV/div. From 100 mV/div to 5 V/div, CMRR is at least 400:1 (52 dB) with up to 100 V peak-to-peak sine wave. | Steps 5 and 6. Check Low- and High-Frequency CMRR. | Steps 5 and 6. Check/Adjust Low- and High-Frequency CMRR. |
| AC (Capacitive) Coupled 50 μ V/div to 0.5 mV/div | At least 10,000:1 (80 dB) at 5 kHz and above, de- creasing to 400:1 (52 dB) at 10 Hz. | | |
| Displayed Noise (Tangentially Measured) | 30 μ V or less. | Step 9. Check Overall Noise Level Tangentially. | Step 9. Check Overall Noise Level Tangentially. |

Adjustment Interval

To maintain instrument accuracy, check performance every 1000 hours of operation, or every 6 months if used infrequently. Before complete adjustment, thoroughly clean and inspect this instrument as outlined in the Maintenance section.

Tektronix Field Service

Tektronix Field Service Centers and the Factory Service Center provide instrument repair and adjustment services. Contact your Tektronix Field Office or representative for further information.

Preliminary Control Settings

Set 5A21N and oscilloscope system controls as follows:

5A21N

| | |
|--------------------|---|
| DISPLAY | ON (readout illuminates when power is on) |
| POSITION | Midrange |
| BANDWIDTH LIMIT | 1 MHz (button out) |
| CURR PROBE ONLY | VOLTS (button out) |
| VOLTS/DIV | 50 m |
| Variable Volts/Div | CAL detent (fully clockwise) |
| ATTEN STEP BAL | Midrange |
| + Input Coupling | DC, GND |
| - Input Coupling | DC, GND |

Oscilloscope

| | |
|----------------------|--|
| Mainframe | |
| Intensity | Normal display brightness |
| Focus | Adjust for best focus of trace |
| Time Base | |
| Display | Alt (button out) |
| Position | Sweep starts at left edge of graticule |
| Seconds/Div | 1 m |
| Variable Seconds/Div | Cal detent |
| Swp Mag | Off (button out) |
| Triggering Mode | Auto Trig, AC Coupling, + Slope |
| Triggering Source | Left |
| Triggering Level | Midrange |

1. Check/Adjust Variable Balance (R159)

- a. Move the trace to the graticule center horizontal line with the POSITION control.
- b. Rotate the Variable Volts/Div (CAL) control counterclockwise.
- c. EXAMINE—Trace should not shift more than one division as the CAL control is rotated throughout its range.
- d. ADJUST—R159, Var Bal, for minimum trace shift as the CAL control is rotated throughout its range. See Fig. 5-1 for adjustment location. Re-adjustment of the POSITION control may be necessary to return the trace to graticule center after the minimum shift has been attained.
- e. Return the CAL control to the fully clockwise position.

2. Check/Adjust DC Balance (R227)

- a. Turn the VOLTS/DIV switch throughout its range.
- b. CHECK—The trace for one division of shift or less. Adjust the front-panel ATTEN STEP BAL control for minimum trace shift as the VOLTS/DIV switch is rotated throughout its range. Readjust the POSITION control, if necessary, to return the trace to graticule center after minimum shift has been attained.
- c. If balance cannot be achieved, center the ATTEN STEP BAL control and turn the VOLTS/DIV switch throughout its range.
- d. ADJUST—R227, Bal, for minimum trace shift. See Fig. 5-1 for adjustment location. If the trace goes off-screen at higher sensitivities, start at the position of the VOLTS/DIV switch at which an on-screen display is obtained and adjust R227, Bal, working down to the 50 μ V position, so the trace remains on-screen at 50 μ V. Make the fine adjustment to bring the trace to screen center with the front-panel ATTEN STEP BAL control. Maximum allowable shift of the trace is one division as the VOLTS/DIV switch is rotated.

3. Check/Adjust Amplifier Gain (R268) and Check VOLTS/DIV Switch Accuracy

- a. Connect the standard amplitude calibrator output connector to the + input connector through a coaxial cable. Set the standard amplitude calibrator for a 50 mV square-wave output.
- b. Set the VOLTS/DIV switch to 10 mV and release the + Input Coupling GND (button out).
- c. CHECK—Display amplitude is five divisions, ± 0.1 division. Adjust positioning as required.
- d. Adjust—R268, Gain, for a display amplitude of exactly five divisions. See Fig. 5-1 for adjustment location.
- e. Rotate the variable Volts/Div (CAL) control fully counterclockwise.
- f. EXAMINE—The display amplitude for two divisions or less.
- g. Return the Variable Volts/Div (CAL) control to its fully clockwise detent.

Test Equipment Required

The test equipment listed in Table 5-3 is required for a complete Adjustment and Performance Check of the instrument. The specifications for test equipment, given in Table 5-3, are the minimum required to meet the performance requirements. Substitute equipment must meet or exceed the stated requirements. All test equipment is assumed to be operating within tolerance. Detailed operating instructions to test equipment are omitted in these procedures. Refer to the test equipment instruction manual if more information is needed.

Special Fixtures

Special fixtures are used only where they facilitate instrument adjustment. These fixtures are available from Tektronix, Inc. Order by part number from Tektronix Field Offices or representatives.

Test Equipment Alternatives

All of the listed test equipment is required to completely calibrate this instrument. However, complete checking or adjusting may not always be necessary or desirable. You may be satisfied with checking only selected characteristics, thereby reducing the amount of test equipment actually required.

The calibration procedures in Part I and Part II are based on the first item of equipment given as an example. When other equipment is substituted, control settings or setups may need to be altered. If the exact item of equipment given as an example in Table 5-3 is not available, first check the Minimum Specifications column carefully to see if any other equipment might suffice. Then check the Purpose column to see what this item is used for. If used for a performance check or adjustment that is of little or no importance for your measurement requirements, the item and corresponding step(s) can be deleted.

Table 5-3
TEST EQUIPMENT

| Description | Minimum Specifications | Purpose | Examples of Applicable Test Equipment |
|----------------------------------|--|---|---|
| 1. Oscilloscope Mainframe | TEKTRONIX 5000-series oscilloscope. | Used throughout procedures to provide display. | a. TEKTRONIX 5110 Oscilloscope. b. TEKTRONIX 5111, 5115, 5440, or 5441 Oscilloscope. |
| 2. Time Base | TEKTRONIX 5B-series time-base plug-in unit. | Used throughout procedures to provide sweep. | a. TEKTRONIX 5B10N or 5B12N Time-Base. b. TEKTRONIX 5B40 or 5B42 Time-Base (must use 5440 or 5441 Oscilloscope). |
| 3. Standard Amplitude Calibrator | Amplitude accuracy, within 0.25% into 1 M Ω ; range, 0.2 mV to 100 V; output, dc and square wave at approximately 1 kHz; must have a 5 mA current loop. Fast risetime square-wave output, variable 0.5 V to 5 V, ≤ 10 ns risetime, $\leq 2\%$ aberrations, all terminated into 50 Ω . | Check/Adjust amplifier gain and attenuator accuracy. Check/adjust input compensation. Check dc rejection, noise level and probe amplifier gain. | a. TEKTRONIX PG 506 Calibration Generator with TM 500-series Power Module. |
| 4. Sine-Wave Generator | Frequency, 2 Hz to 1 MHz; amplitude, variable from 0.5 V to 10 V into 50 Ω and to 20 V open circuit. | Check CMRR and frequency response. | a. TEKTRONIX FG 503 Function Generator with TM 500-series Power Module. |
| 5. 1000:1 Divider | Accuracy, 1000:1 $\pm 0.2\%$; switchable X1 to X1000; connectors, bnc. | Check attenuator accuracy. | a. Tektronix 067-0529-00 Calibration Fixture. |

PART II— ADJUSTMENT AND PERFORMANCE CHECK

The following procedure (Part II—Adjustment and Performance Check) provides the information necessary to: (1) verify that the instrument meets the electrical specifications, (2) verify that the controls function properly, and (3) perform all internal adjustments.

Part I—Performance Check verifies that the instrument meets the electrical specifications without making internal adjustments. All tolerances given are as specified in the Specification tables (section 1) in this manual.

A separate Checkout Procedure is provided in section 2 for instrument familiarization and also to verify that the controls function properly.

See Table 5-1 (Calibration Procedure Electives) at the beginning of this section, for information on performing a Partial Part II—Adjustment and Performance Check Procedure.

INDEX TO PART II— ADJUSTMENT AND PERFORMANCE CHECK

| | Page |
|--|-------------|
| 1. Check/Adjust Variable Balance (R159) | 5-13 |
| 2. Check/Adjust DC Balance (R227) | 5-13 |
| 3. Check/Adjust Amplifier Gain (R268) and Check Volts/Div Switch Accuracy | 5-13 |
| 4. Check/Adjust Input Compensation (C1, C2, C3, C11, C12, C13) | 5-14 |
| 5. Check/Adjust Attenuator Low Frequency CMRR (R109) | 5-15 |
| 6. Check/Adjust High Frequency CMRR (C221, C250) | 5-16 |
| 7. Check Amplifier Bandwidth | 5-16 |
| 8. Check Input Gate Current and DC Rejection . . | 5-16 |
| 9. Check Overall Noise Level Tangentially | 5-17 |
| 10. Check Current Probe Amplifier Gain | 5-17 |
| 11. Check Current Probe Amplifier Frequency Response | 5-18 |

PRELIMINARY PROCEDURE FOR ADJUSTMENT AND PERFORMANCE CHECK

Before performing this procedure, temporarily remove any user modification of the instrument to avoid a possible conflict with the procedure. As an example: the optional high impedance input and the optional bandwidth limiting frequencies modifications, that are described in this manual, are changes that may have been installed.

1. Remove the dust cover from the left side of the 5A21N and remove the cabinet panel from the left side of the oscilloscope mainframe.



To avoid instrument damage, it is recommended that the POWER switch be turned off before removing or replacing plug-in units.

2. Connect the 5A21N to a plug-in extender and connect the extender to the left plug-in compartment of the 5110 Oscilloscope mainframe. Insert a time-base unit into the right compartment.

3. Connect the oscilloscope to the power source for which it is wired and turn on the POWER switch. Allow at least 20 minutes warmup before beginning the procedure.

4. Set the controls as given under Preliminary Control Settings.

NOTE

The performance of this instrument can be checked at any ambient temperature from 0°C to +50°C unless otherwise stated. Adjustments must be performed at an ambient temperature between +20°C and +30°C for specified accuracies.

(Description) DIFFERENTIAL AMPL. (DED)
 (Mfr) TEKTRONIX (TEA)
 (Model) SAZIN

CALIBRATION PROCEDURE

SECTION 1

INTRODUCTION AND DESCRIPTION

1.1 This procedure describes the calibration of the TEKTRONIX SAZIN DIFFERENTIAL AMPL.. The instrument being calibrated will be referred to herein as the Test Instrument (TI).

TABLE 1. CALIBRATION DESCRIPTION

| Test Instrument Characteristics | Performance Specifications | Test Method |
|---------------------------------|---|--|
| DEFLECTION FACTOR | 50mV to 5V/DIV $\pm 2\%$ 0.5mA to 0.5A/DIV $\pm 3\%$ | COMPARE TO STANDARD AMPLITUDE CALIBRATOR SIGNAL. |
| FREQ. RESPONSE (-3dB POINT) | DC: DC TO 1MHZ AC: 2HZ TO 1MHZ | COMPARE TO SIGNAL FROM CONSTANT AMPLITUDE SIG. GEN. |
| COMMON MODE REJECTION | DC: $\geq 100dB$ 50mV + 100mV/DIV, DECREASING $< 20dB$ PER DECADE TO 50mV/DIV; $\geq 50dB$ 100mV - 5V/DIV. AC: $\geq 80dB$ 5KHZ - 1MHZ DECREASING TO 50dB AT 10HZ. | MEASUREMENT OF DISPLAY AMPLITUDE WITH SAME SIGNAL APPLIED TO BOTH INPUTS SIMULTANEOUSLY. |

SECTION 2

PROCEDURE STARTS ON PAGE 5-7 AND ENDS ON PAGE 5-11

EQUIPMENT REQUIREMENTS

Note

Minimum use specifications are the principal parameters required for performance of the calibration and are included to assist in the selection of alternate equipment. The selection of equipment other than that designated is the responsibility of the supervisor of the calibrating activity. Correct performance of alternate items should be verified by operational tests. All applicable equipment must bear evidence of current calibration.

b. Set the standard amplitude calibrator for a 0.1 V square-wave output and turn the variable attenuator control fully clockwise.

c. Change the following control settings:

| | |
|---------------------------------|------------------------------------|
| VOLTS/DIV | 50 μ V |
| BANDWIDTH LIMIT | 1 MHz (button out) |
| + Input Coupling | DC |
| – Input Coupling | GND |
| Seconds/Div (time-base) | .5 ms |
| Triggering Level (time base) | Clockwise (untriggered display) |

d. Turn the variable attenuator control slowly counterclockwise and observe two noise bands displayed on the crt (noise and free-running square wave). Continue to turn the variable attenuator control until the two noise bands merge (just to the point at which the dark band between the two noise bands disappears).

e. Remove the two 10X attenuators and connect the variable attenuator directly to the 50 Ω termination.

f. Switch the VOLTS/DIV switch to any position that will give a convenient display (two traces).

g. CHECK—The vertical amplitude of the display. Calculate the tangentially measured noise by dividing the measured display by 100. For example, two divisions of display at 0.5 mV per division is equal to 1 mV. One mV divided by 100 is equal to 10 μ V of tangentially measured noise. Maximum noise, 30 μ V.

h. Disconnect all test equipment.

10. Check Current Probe Amplifier Gain

a. Change the control settings as follows:

| | |
|----------------------------|--------------------------------|
| Volts-Amperes Mode | CURR PROBE ONLY (button in) |
| AMPERES/DIV | 1 mA |
| Seconds/Div (time base) | 1 ms |

b. Set the standard amplitude calibrator for a 5 mA output at the current loop of the generator.

c. Connect a 125-turn current probe (P6021) to the 125 TURN PROBE input connector and connect the probe tip to the 5 mA current loop of the standard amplitude calibrator. Adjust the Triggering Level control for a stable display.

d. CHECK—Five divisions, $\pm 3\%$, of vertical display.

11. Check Current Probe Amplifier Frequency Response

a. Connect a GR-to-bnc male adapter to the sine-wave generator output. Connect a high-frequency current test fixture to the adapter. Connect the 125-turn current probe to the test fixture.

b. Change the time-base Seconds/Div switch to .5 ms.

c. Adjust the sine-wave generator for eight vertical divisions of 1 kHz display as a reference. Then slowly increase the frequency until the display amplitude is 5.66 divisions. This is the upper -3 dB point.

d. CHECK—Frequency is at least 1 MHz.

e. Set the BANDWIDTH LIMIT to 10 kHz (button in) and adjust the sine-wave generator for eight vertical divisions of 2 kHz reference display. Then slowly increase the frequency until the display amplitude is 5.66 divisions.

f. CHECK—Frequency at the upper -3 dB point (bandwidth limited) is between 8 kHz and 12 kHz.

g. Release the BANDWIDTH LIMIT switch (button out) and adjust the sine-wave generator for eight vertical divisions of 2 kHz reference display. Then slowly decrease the frequency until the display amplitude is 5.66 divisions. This is the lower -3 dB point. Set the time-base Seconds/Div switch as necessary to view the signal.

h. CHECK—Frequency is 15 Hz or less.

i. Disconnect all test equipment.

This completes the Part I—Performance Check procedure.

PART I— PERFORMANCE CHECK

The following procedure (Part I—Performance Check) verifies electrical specifications without making internal adjustments. All tolerances given are as specified in the Specification tables (section 1) in this manual.

Part II—Adjustment and Performance Check provides the information necessary to: (1) verify that the instrument meets the electrical specifications (2) verify that the controls function properly, and (3) perform all internal adjustments.

A separate Checkout Procedure is provided in section 2 to provide instrument familiarization and to verify that the controls function properly.

See Table 5-1, Calibration Procedure Electives, at the beginning of this section, for information on performing a Partial Part I—Performance Check procedure.

INDEX TO PART I— PERFORMANCE CHECK

| | Page |
|--|-------------|
| 1. Check Variable Balance | 5-8 |
| 2. Check DC Balance | 5-8 |
| 3. Check Amplifier Gain and VOLTS/DIV Switch Accuracy | 5-8 |
| 4. Check Input Compensation | 5-9 |
| 5. Check Attenuator Low-frequency CMRR | 5-9 |
| 6. Check High Frequency CMRR | 5-9 |
| 7. Check Amplifier Bandwidth | 5-9 |
| 8. Check Input Gate Current and DC Rejection | 5-10 |
| 9. Check Amplifier Noise Level Tangentially | 5-10 |
| 10. Check Current Probe Amplifier Gain | 5-11 |
| 11. Check Current Probe Amplifier Frequency Response | 5-11 |

PRELIMINARY PROCEDURE FOR PERFORMANCE CHECK

Before performing this procedure, temporarily remove any user modification of the instrument to avoid a possible conflict with the procedure. As an example: the optional high impedance input and the optional bandwidth limiting frequencies modifications, which are described in this manual, are changes that may have been installed.

1. Insert the 5A21N into the left plug-in compartment of the oscilloscope mainframe. Insert a time-base unit into the right compartment.



To avoid instrument damage, it is recommended that the POWER switch be turned off before removing or replacing plug-in units.

2. Connect the oscilloscope to the power source for which it is wired and turn on the POWER switch. Allow at least 20 minutes warmup before beginning the procedure.

3. Set the controls as given under Preliminary Control Settings.

NOTE

The Electrical Characteristics in this section are valid only if the oscilloscope has been calibrated at an ambient temperature between +20° C and +30° C and is operating at an ambient temperature between 0° C to +50° C.

Preliminary Control Settings

Set the 5A21N and oscilloscope system controls as follows:

5A21N

| | |
|--------------------|---|
| DISPLAY | ON (readout illuminates when power is on) |
| POSITION | Midrange |
| BANDWIDTH LIMIT | 1 MHz (button out) |
| CURR PROBE ONLY | VOLTS (button out) |
| VOLTS/DIV | 50 m |
| Variable Volts/Div | CAL detent (fully clockwise) |
| ATTEN STEP BAL | Midrange |
| + Input Coupling | DC, GND |
| – Input Coupling | DC, GND |

Calibration—5A21N

b. Change the controls as follows:

| | |
|-------------------------|-------|
| VOLTS/DIV | .1 V |
| + Input Coupling | AC |
| – Input Coupling | GND |
| Seconds/Div (time-base) | .5 ms |

c. Adjust the sine-wave generator for eight vertical divisions of 1 kHz display as a reference. Then slowly increase the frequency until the display amplitude is 5.66 divisions. This is the upper –3 dB point.

d. CHECK—Frequency at the upper –3 dB point must be at least 1 MHz.

e. Set the BANDWIDTH LIMIT to 10 kHz (button in) and adjust the sine-wave generator for eight vertical divisions of 2 kHz reference display. Then slowly increase the frequency until the display is 5.66 divisions.

f. CHECK—Frequency at the upper –3 dB point (bandwidth limited) is between 8 kHz and 12 kHz.

g. Release the BANDWIDTH LIMIT switch (button out) and adjust the sine-wave generator for eight vertical divisions of 2 kHz reference display. Then slowly decrease the frequency until the display amplitude is 5.66 divisions. This is the lower –3 dB point when AC coupling is used (determined by the coupling capacitor). Set the time-base Seconds/Div as necessary to view the signal.

h. CHECK—Frequency at the lower –3 dB point is 2 Hz or less.

i. Disconnect the sine-wave generator.

8. Check Input Gate Current and DC Rejection

a. Position the trace to the graticule center, then change the following control settings:

| | |
|-------------------------|------------|
| BANDWIDTH LIMIT | 10 kHz |
| VOLTS/DIV | 50 μ V |
| + Input Coupling | AC, GND |
| – Input Coupling | AC, GND |
| Seconds/Div (time-base) | 1 ms |

b. Connect a 50 Ω termination to the + input connector and using the ATTEN STEP BAL control, position the trace to the graticule centerline.

c. Release the GND button of the + Input Coupling switch (input AC-coupled) and allow a few seconds for the display to stabilize.

d. CHECK—Trace shift is less than ± 2 divisions. This indicates an input gate current of 100 pA or less.

e. Ground the + Input Coupling (GND button in) and move the 50 Ω termination to the – input connector.

f. Release the GND button of the – Input Coupling switch.

g. CHECK—Trace shift is less than ± 2 divisions.

h. Remove the 50 Ω termination, release the GND button of the + Input Coupling switch, and position the display to graticule center (both the + and – Input Coupling switches should be set to AC and ungrounded).

i. Set the standard amplitude calibrator for a 5 V dc output (see the instruction manual for the amplitude calibrator to convert to dc output).

j. Connect the standard amplitude calibrator output connector to the + input connector through a coaxial cable and allow at least 10 seconds for the display to stabilize.

k. CHECK—Trace shift is ± 1 division or less. This indicates an input dc rejection ratio of 100,000:1.

l. Move the cable to the – input and allow the display to stabilize.

m. CHECK—Trace shift is ± 1 division or less.

n. Disconnect the coaxial cable and return the standard amplitude calibrator to square-wave output operation.

9. Check Overall Noise Level Tangentially

a. Connect the standard amplitude calibrator output directly to a GR-to-bnc male adapter, then connect a variable attenuator (with arrow on variable attenuator pointing away from the calibrator output). Connect also in sequence to the signal setup, a GR-to-bnc female adapter, a coaxial cable, two 10X attenuators, a 50 Ω termination, then to the + input connector.

Calibration—5A21N

Oscilloscope

| | |
|----------------------|--|
| Mainframe | |
| Intensity | Normal display brightness |
| Focus | Adjust for best focus of trace |
| Time Base | |
| Display | Alt (button out) |
| Position | Sweep starts at left edge of graticule |
| Seconds/Div | 1 m |
| Variable Seconds/Div | Cal detent |
| Swp Mag | Off (button out) |
| Triggering Mode | Auto Trig, AC Coupling, + Slope |
| Triggering Source | Left |
| Triggering Level | Midrange |

1. Check Variable Balance

a. Move the trace to the graticule center horizontal line with the POSITION control.

b. Rotate the Variable Volts/Div (CAL) control counterclockwise.

c. EXAMINE—Trace should not shift more than one division as the CAL control is rotated throughout its range.

d. Return the CAL control to the fully clockwise detent position.

2. Check DC Balance

a. Turn the VOLTS/DIV switch throughout its range.

b. CHECK—Trace should not shift more than one division. Adjust the front-panel ATTEN STEP BAL control for minimum trace shift as the VOLTS/DIV switch is rotated throughout its range. Readjust the POSITION control, if necessary, to return the trace to graticule after minimum shift has been attained.

3. Check Amplifier Gain and VOLTS/DIV Switch Accuracy

a. Connect the standard amplitude calibrator output connector to the + input connector through a coaxial cable. Set the standard amplitude calibrator for a 50 mV square-wave output of 1 kHz.

b. Set the VOLTS/DIV switch to 10 mV and release the + Input Coupling GND (button out).

c. CHECK—Display amplitude is five divisions, ± 0.1 division. Adjust the POSITION control as required.

d. Rotate the variable Volts/Div (CAL) control fully counterclockwise.

e. EXAMINE—The display amplitude for two divisions or less.

f. Return the variable Volts/Div (CAL) control to its fully clockwise detent.

g. CHECK—Using the VOLTS/DIV switch and standard amplitude calibrator switch settings given in Table 5-4, check the VOLTS/DIV switch accuracy. Set the BANDWIDTH LIMIT switch to 10 kHz for the more sensitive positions.

**Table 5-4
VOLTS/DIVISION ACCURACY**

| VOLTS/DIV Switch Setting | Standard Amplitude Calibrator Output | CRT Display (Vertical Deflection) |
|---|---|--|
| 5 V | 20 volts | 4 div, ± 0.08 div |
| 2 V | 10 volts | 5 div, ± 0.1 div |
| 1 V | 5 volts | 5 div, ± 0.1 div |
| .5 V | 2 volts | 4 div, ± 0.08 div |
| .2 V | 1 volt | 5 div, ± 0.1 div |
| .1 V | .5 volt | 5 div, ± 0.1 div |
| 50 mV | .2 volt | 4 div, ± 0.08 div |
| 20 mV | .1 volt | 5 div, ± 0.1 div |
| 10 mV | 50 mV | 5 div, ± 0.1 div |

Connect a 1000:1 divider between the calibrator output and the + input connector to check higher sensitivity ranges.

| | | |
|------------|------|-----------------------|
| 5 mV | 20 V | 4 div, ± 0.08 div |
| 2 mV | 10 V | 5 div, ± 0.1 div |
| 1 mV | 5 V | 5 div, ± 0.1 div |
| .5 mV | 2 V | 4 div, ± 0.08 div |
| .2 mV | 1 V | 5 div, ± 0.1 div |
| .1 mV | .5 V | 5 div, ± 0.1 div |
| 50 μ V | .2 V | 4 div, ± 0.08 div |

h. Remove the 1000:1 divider and coaxial cable.

4. Check Input Compensation

a. Connect a 47 pF input RC normalizer to the + input connector, then connect a 50 Ω termination between the normalizer and signal cable. Set the VOLTS/DIV switch to .1 V and the BANDWIDTH LIMIT to 1 MHz (button out).

b. Set the standard amplitude calibrator for a five-division display of a fast-risetime, 1 kHz square-wave signal.

c. CHECK—Optimum square leading corner at top of the square-wave display. Aberrations are not to exceed + or - 2%, or 3% total (peak-to-peak).

d. Change the VOLTS/DIV switch to 50 mV and adjust the standard amplitude calibrator for a five-division display.

e. CHECK—Optimum square leading corner at top of the square-wave display. Aberrations are not to exceed + or - 2%, or 3% total.

f. Move the RC normalizer, termination and cable setup from the + input to the - input.

g. Set the + Input Coupling to GND and the - Input Coupling to DC. Position the display to the center of the graticule area.

h. Set the VOLTS/DIV switch to .1 V and set the standard amplitude calibrator for a five-division display.

i. CHECK—Optimum square leading corner at bottom of the square-wave display. Aberrations are not to exceed + or - 2%, or 3% total.

j. Change the VOLTS/DIV switch to 50 mV and adjust the standard amplitude calibrator for a five-division display.

k. CHECK—Optimum square leading corner at bottom of the square-wave display. Aberrations are not to exceed + or - 2%, or 3% total.

l. Disconnect the RC normalizer and standard amplitude calibrator setup.

5. Check Attenuator Low-Frequency CMRR

a. Set the controls as follows:

| | |
|-------------------------|------|
| VOLTS/DIV | 5 V |
| + Input Coupling | DC |
| - Input Coupling | GND |
| Seconds/Div (time-base) | 5 ms |

b. Connect a dual input cable to the + and - input connectors. Connect a sine-wave generator output to the dual-input cable through a coaxial cable.

c. Set the sine-wave generator for a 100 Hz, 20 V peak-to-peak reference signal (set to obtain four divisions of vertical deflection).

d. Set the - Input Coupling to DC (both the + and - Input Coupling switches should now be set to DC, ungrounded) and set the VOLTS/DIV switch to 50 μ V.

e. CHECK—The display for four divisions or less of 100 Hz signal (disregard trace noise).

f. Change the sine-wave generator frequency to 1 kHz.

g. CHECK—The display for four divisions or less of 1 kHz signal (disregard trace noise).

6. Check High-Frequency CMRR

a. Set the sine-wave generator for a 20 V, 30 kHz output (set the VOLTS/DIV switch to 5 V, - Input Coupling to GND and obtain four vertical divisions of display).

b. Set the - Input Coupling to DC and VOLTS/DIV switch to 50 mV. Set the time base seconds/div switch to 1 ms.

c. CHECK—Vertical deflection for all VOLTS/DIV switch ranges from 50 mV to .1 mV is two divisions or less; for 50 μ V, four divisions or less.

d. Disconnect the signal setup.

7. Check Amplifier Bandwidth

a. Set the sine-wave generator for minimum output amplitude and connect the generator output to the + input connector through a coaxial cable.